



MOUNT LAWLEY SENIOR HIGH SCHOOL
An Independent Public School

2027 Course Information Handbook

Year 11 and 12 Pathways

THE JOURNEY CONTINUES
GOOD TO GREAT

At Mount Lawley Senior High School, the Senior School responds flexibly to the diverse needs of students and provides an innovative, inclusive and adult learning environment. Our approach values and respects every student, supporting them to develop the skills, knowledge and confidence needed to achieve their full potential and prepare for future success.

The school has a proud tradition of academic excellence and high achievement, while recognising the importance of providing a wide range of pathways to suit individual interests, strengths and career aspirations. As one of Western Australia's leading public secondary schools, Mount Lawley Senior High School continues to be recognised as a showcase for exemplary secondary education.

Students are offered a broad range of opportunities and pathways, including:

- Pathways leading to university, TAFE and other tertiary or training institutions;
- Vocational Education and Training (VET) programs and workplace learning opportunities; and
- Programs that combine school studies with TAFE, other training providers and work placements.

Mount Lawley Senior High School remains at the forefront of curriculum innovation, offering an extensive range of courses designed to meet the evolving needs of contemporary learners. Our Senior School combines strong traditional foundations with engaging and future-focused learning experiences that encourage students to become independent, resilient and lifelong learners.

A comprehensive counselling and course selection program supports all Year 10 students as they consider their Year 11 and 12 pathways. This process is centred on helping students make informed choices that align with their interests, abilities and future goals. Parents and caregivers are strongly encouraged to engage in this process and work in partnership with staff to support students in selecting courses that provide the best opportunity for success.

Maria Camilleri
Associate Principal – Senior School

- 4 Key Terms
- 6 Enrolling in Year 11 and Year 12
- 6 WACE (Western Australian Certificate of Education)
- 6 Pathways
- 7 Course Choices
- 7 Alternative University Entry
- 8 List A and List B Courses
- 9 University Admission Requirements for School Leavers
- 9 Vocational Education & Training (VET)
- 10 VET Certificate Offerings
- 10 Career Link Program (VETDSS) Commencement & Structure
- 12 Aboriginal School Based Traineeships
- 12 Unique Student Identifier (USI)
- 13 Career, TAFE & WA University Contacts
- 13 Online Resources

- 14 Arts Courses
- 26 English Courses
- 34 Health and Physical Education Courses
- 40 Humanities & Social Sciences (HASS) Courses
- 58 Career & Employability and Workplace Learning
- 59 Language Courses
- 66 Mathematics Courses
- 71 Science Courses
- 76 Technologies Courses

- 87 Vocational Education & Training
- 88 Career Link Program
- 89 Certificate Qualifications

The information in this handbook is current at time of publication but is subject to change due to prescribed changes made by state authorities.

KEY TERMS

ATAR (Australian Tertiary Admission Rank)

An ATAR is calculated using the school assessment and the student's best four scaled course scores, plus bonuses where applicable. The ATAR is used to determine eligibility for university entrance. (Australia wide)

ATAR course (subject)

An ATAR course is offered in Years 11 and 12. The Year 11 course consists of Units 1 and 2 and the Year 12 course consists of Units 3 and 4. Year 12 ATAR courses are examined by the School Curriculum and Standards Authority (SCSA) at the completion of Year 12.

Course (often referred to as a subject)

A course is a program of study in a particular subject offered at two year levels. It consists of a Year 11 syllabus, comprising of Units 1 and 2 and a Year 12 syllabus, comprising Units 3 and 4.

Endorsed Programs

Endorsed programs provide access to areas of learning not covered by WACE courses or vocational education and training (VET) programs. They are delivered in a variety of settings by schools, workplaces, universities and community organisations. These programs contribute to the WACE.

Externally Set Task (EST)

An externally set task (EST) is conducted for each General course in Year 12. The EST is compulsory for all students enrolled in Units 3 and 4. All ESTs are set by SCSA. An EST is conducted under exam conditions generally in Semester One exams.

General Course (subject)

A General course is offered at two year levels, each with its own syllabus. The Year 11 syllabus comprises Units 1 and 2, and Year 12 syllabus comprises Units 3 and 4. General courses are designed for students who are typically aiming to enter further vocationally based training or the workforce directly from school.

Grades

Grades indicate the level of the student's performance: A (highest), B, C, D and E.

National Assessment Program - Literacy and Numeracy (NAPLAN)

NAPLAN is an assessment of literacy and numeracy and is undertaken annually by all Year 3, 5, 7 and 9 students throughout Australia. In Western Australia, students who sat NAPLAN prior to 2022, who achieve Band 8 or higher in the associated components of the Year 9 NAPLAN are deemed to have demonstrated the literacy and numeracy standard for the WACE.

Online Literacy and Numeracy Assessment (OLNA)

The OLNA assesses skills described in Levels 1–4 of the Australian Core Skills Framework. The skills described are those regarded as essential for individuals to meet the demands of everyday life and work. Demonstrating the literacy and numeracy standard is one requirement for achieving a WACE.

The OLNA is sat by students in the first semester of Year 10. Students who do not demonstrate the standard at their first attempt of the OLNA have the opportunity to sit it again in September of Year 10 and thereafter on two occasions in Year 11 and two occasions in Year 12. They may also sit the OLNA subsequently in any year after compulsory schooling if they have not yet met the standard.

NOTE: Students who achieve Band 8 or higher in Year 9 NAPLAN Reading, Writing or Numeracy assessments will be prequalified for that component and will not be required to sit the corresponding OLNA component. For example, if a student achieves Band 8 for Reading and Numeracy but not for Writing, they will only be required to sit the OLNA Writing component.

Registered Training Organisation (RTO)

An RTO is an organisation that delivers, assesses, certifies and quality assures a nationally recognised VET qualification. An RTO may be a school, a private training provider, or a TAFE. All RTOs operate under the various elements of the national training system.

Subject

A subject is a discrete area of study within a particular learning area. A subject is delivered in the form of ATAR and General courses. The different courses fulfil different purposes and emphasise different aspects of the subject.

VET (Vocational Education and Training)

Vocational education and training enables students to acquire workplace skills through nationally recognised training described within an industry developed training package or accredited course.

VETDSS (VET courses Delivered to Secondary Students)

The Career Link Program (VETDSS) is a school-based training program and is intended as a transition from school to an apprenticeship. It provides an introduction into the apprenticeship opportunities within various trades.

WACE (Western Australian Certificate of Education)

The Western Australian Certificate of Education (WACE) is awarded by the School Curriculum and Standards Authority to students in Western Australia on successful completion of their senior secondary education. WACE requirements may change over time and students studying towards the achievement of the WACE after they leave school will be required to meet the WACE requirements current at the time of the completion of their studies.

WASSA (Western Australian Statement of Student Achievement)

A Western Australian Statement of Student Achievement (WASSA) is issued to all Year 12 students at the completion of their secondary schooling. The WASSA lists all courses and programs that a student has completed.

ENROLLING IN YEAR 11 AND YEAR 12

The courses you choose for Year 11 and 12 need careful consideration as you need to be aware of the:

- requirements for achievement of the Western Australian Certificate of Education (WACE);
- requirements for University Entrance or TAFE; and
- post-secondary options in education and training.

There has to be a balance of:

- knowing the rules and regulations of the School Curriculum and Standards Authority (SCSA);
- meeting the prerequisites of the various post-secondary courses; and
- consideration of your interests, abilities and academic achievement so far.

WACE (Western Australian Certificate of Education)

Students must meet all of the following requirements of WACE.

Literacy and Numeracy Requirements	Meet the Literacy and Numeracy standards through NAPLAN or OLNA as well as complete 4 units of English, two in Year 12.
Course / Endorsed Program Achievement	Complete a minimum of 20 units (or equivalents) including a minimum of 10 Year 12 units or equivalent.
Achievement Standard	Achieve a minimum of 14 C grades in Year 11 and Year 12 units (or equivalents) including at least 6 C grades in Year 12 units (or equivalents).
Breadth and Depth	Choose at least 1 course from List A and List B courses in Year 12.
Examination	WACE courses: all students in their final year who are enrolled in ATAR courses will sit compulsory exams.

PATHWAYS

Students will be counselled in Year 10 into course selections which lead to a range of career paths.

If you wish to pursue a particular course at University you need to meet prerequisites of at least 4 ATAR courses in both Year 11 and 12. One of those courses must be ATAR English, Literature or EAL/D. Studying these will allow students to sit exit exams at the end of Year 12, which will then give you a TEA for entry to further study at University. University requirements can be found in the various university handbooks available online or at school. Students are highly encouraged to undertake at least four ATAR courses in Year 12. For Year 11 students, Year 10 results are the best guide to assist in selecting courses. Many Year 11 courses have a recommended background. It is important to be aware of these recommendations.

It is not necessary to study the same courses in Year 12 that were studied in Year 11. However, it is important to realise that to succeed in many Year 12 courses it is helpful to have studied the Year 11 course in order to have a solid foundation. The external exams are for progress towards university studies. All courses will contribute to meeting WACE requirements and pathways to either TAFE, an apprenticeship or employment.

YEAR 11 and 12 Pathways

COURSE CHOICES

ATAR Courses

These courses are generally taken by students seeking entry to university. This does not mean that you should not choose them if you are seeking entry to TAFE or employment. In fact, some TAFE courses and employers list ATAR courses as prerequisite courses. Students studying these courses must sit exit exams at the end of Year 12. Year 12 students who know they want to go to university must choose at least four ATAR courses including ATAR English. ATAR courses may have additional expenses such as purchase of booklist texts.

General Courses

These courses are normally chosen by students who wish to seek entry to TAFE or employment. They are often more practically based. Students on an ATAR pathway may wish to consider a General course as a sixth course. General courses do not have an external exam component.

Vocational Education and Training (VET)

This qualification gives students the opportunity to gain skills and knowledge in the workplace while working towards graduation. Students choosing a VET qualification shall attain certain competencies and skills recognised by an employer and receive a nationally accredited qualification. Simply, you are able to gain a nationally recognised industry qualification whilst completing your Western Australian Certificate of Education.

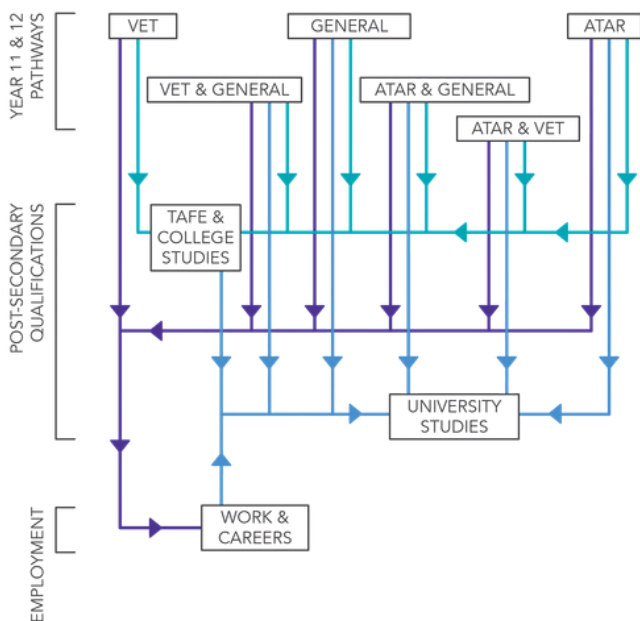

ALTERNATIVE UNIVERSITY ENTRY

WA Universities have a number of alternative entry pathways that provide you with options if your results or educational background do not provide immediate eligibility for direct entry to undergraduate study.

Pathways include preparation, enabling and bridging courses, experience-based entry, portfolio entry, mature-age entry (aged 20 or over before 1 March in the admission year), first in family entry, pathways for Aboriginal and/or Torres Strait Islander students, and pathways that recognise prior learning and professional experience.

Additionally, students with TAFE qualifications can apply for credits/advanced standing for the units completed in Diploma or Advanced Diploma programs, when enrolling at university. This pathway could result in a reduction in the length of the university course (and therefore HECS debt).

For more information visit the Alternative University Entry page of the TISC website.

YEAR 11 and 12 Pathways

Course Information Handbook 2027

LIST A AND LIST B COURSES

The below courses are on offer for Year 11 students in 2027. Students must choose **at least one course from each list**.

LIST A - Humanities (Arts, Languages & Social Sciences)

HIA	Ancient History	GEO	Geography
BME	Business Management & Enterprise	HEA	Health Studies
CEM	Career and Enterprise	ISL	Italian: Second Language
CSL	Chinese: Second Language	JSL	Japanese: Second Language
CFC	Children, Family & the Community	KSL	Korean: Second Language
CFL	Chinese: First Language	LIT	Literature
DRA	Drama	MPA	Media Production and Analysis
ECO	Economics	HIM	Modern History
ENG	English	MUS	Music
ELD	English as an Additional Language	PAL	Politics and Law
FST	Food Science & Technology	VAR	Visual Arts
FSL	French: Second Language	AIS	Aboriginal and Intercultural Studies

LIST B - STEM (Science, Technologies, Engineering & Mathematics)

ACF	Accounting and Finance	MAE	Mathematics Essentials
AIT	Applied Information Technology	MAM	Mathematics Methods
BLY	Biology	MAS	Mathematics Specialist
CHE	Chemistry	MDT	Materials Design & Technology
CSC	Computer Science	OED	Outdoor Education
DES	Design	PES	Physical Education Studies
EST	Engineering Studies	PHY	Physics
HBY	Human Biology	PSY	Psychology
MAA	Mathematics Applications	SIP	Science in Practice

NOTE: It is very important when selecting a course that attention is paid to minimum entry requirements and the teachers' recommendations.

It may not be possible to timetable courses if they are chosen by a very small number of students.

UNIVERSITY ADMISSION REQUIREMENTS FOR SCHOOL LEAVERS

NOTE: This information is accurate at the time of publication and is subject to change.

This document has been produced to inform teachers, students and parents of decisions made to date by the five Western Australian public universities concerning University Admission Requirements using the School Curriculum and Standards Authority Courses.

TISC has published the Admission Requirements for School Leavers brochure however the information may change.

Summary of requirements for admission to all Western Australian universities are available on their websites.

To be considered for university admission as a school leaver an applicant typically, must:

- Achieve the Western Australian Certificate of Education (WACE);
- Achieve competence in English as prescribed by the individual universities;
- Obtain a sufficiently high ATAR/Selection Rank for entry to a particular university and/or course; and
- Satisfy any prerequisites or special requirements for entry to particular courses or other institutions.

Please ensure you access the Tertiary Institutions Service Centre (tisc.edu.au) and the Student Curriculum and Standards Authority (scsa.wa.edu.au) websites regularly to check for updated information.

VOCATIONAL EDUCATION & TRAINING (VET)

VET programs may suit students who like a more practical approach to schooling. VET offers a combination of education and industry training whilst you are in Years 11 and 12. Units of competency, linked to a certificate qualification are part of VET, either delivered at our school or through the Career Link Program at a Trade Training Centre, TAFE or Private Training Organisation.

Certificate qualifications are a pathway to the achievement of WACE and employment for all students. Successful completion of VET certificates may provide students with improved access to TAFE Colleges, traineeships, apprenticeships and future employment. All certificates are aligned with the Australian Qualifications Framework.

Certificate qualification are rigorous and require students to complete just as much work as any General course and in the case of Certificate III and higher, an ATAR course.

Students on a General pathway may select a maximum of two certificate qualifications. Students on a ATAR pathway may select a maximum of one certificate qualification.

Nationally Recognised Qualifications at Mount Lawley Senior High School
Mount Lawley Senior High School partners with Registered Training Organisations (RTO) to deliver nationally recognised qualifications under the Australian Qualifications Framework (AQF). These qualifications are comparable to those delivered by TAFE Colleges and private RTOs.

The advantages for students studying these qualifications at school are:

- can be part of WACE,
- no time away from school with classes to make up for other courses,
- a full qualification is delivered by teachers who know the student on behalf of a RTO,
- it is more cost effective than external TAFE Colleges and RTOs.

To obtain further information about these qualifications, please contact:

David Toothill | Program Coordinator - VET/Careers
david.toothill@education.wa.edu.au
9265 1532

VET CERTIFICATE OFFERINGS 2027

The below qualifications are a proposed offering for the 2027 academic year.

At the time of publication, no agreements have been entered into with a Registered Training Organisation (RTO) for the delivery of these qualifications.

On the basis of interest from students in each of the below qualifications, the school will initiate a formal partnership agreement with a Registered Training Organisation (RTO) for the delivery of the qualification.

Course	Code	School Code
Certificate II in Workplace Skills	BSB20120	CT2WPS
Certificate III in Business [^]	BSB30120	CT3BUS
Certificate II in Engineering Pathways	MEM20422	CT2ENG
Certificate II in Hospitality	SIT20322	CT2HOS
Certificate II in Creative Industries (Live Production)	CUA20225	CT2CILP
Certificate II in Creative Industries (Media Production)	CUA20225	CT2CIM
Certificate III in Music	CUA30920	CT3MUS
Certificate II in Sport Coaching	SIS20321	CT2SPO
Certificate II in Visual Arts (Photography)	CUA20720	CT2VAP
Certificate III in Events	SIT30522	CT3EV

[^] Available only in Year 12 to students who have completed the Certificate II in Workplace Skills.

CAREER LINK PROGRAM (VETDSS) 2027 COMMENCEMENT & STRUCTURE

Through the Career Link Program, VET qualifications Delivered to Secondary Students (VETDSS) are offered by the North and South Metropolitan TAFE Colleges as well as private Registered Training Organisations.

The Career Link Program is a fantastic opportunity for students in Years 11 and 12, and enrolled in the Western Australian Certificate of Education (WACE), to be one step ahead of other young people who want to undertake an apprenticeship, traineeship, further training and education options.

The Career Link Program is a school-based training program. It provides an introduction into training opportunities within various trades and professions. Students will study at school for four days per week and attend TAFE for one day per week. Studies in a certificate qualification will, on completion, contribute towards the WACE, except for specific Certificate IV qualifications.

The industries that may be available in the Career Link Program are:

- Automotive (heavy & light vehicle, auto body refinishing & repair, auto electrical),
- Building & Construction (wall & floor tiling, bricklaying, carpentry & joinery, ceiling fixing, plastering),
- Community Services, Health and Education,
- Hospitality and Tourism,
- Horticulture (landscaping, nursery, turf, gardening),
- Furniture Trades (cabinet making, furniture finishing, upholstery),

YEAR 11 and 12 Pathways

Course Information Handbook 2027

- Light Manufacturing (Cabinet Maker, Floor Covering, Furniture Maker, Glazier and Glass Processor, Timber Furniture Polisher, Upholsterer, Wood Machinist),
- Metals and Engineering (plant, fabrication and mechanical fitting),
- Personal Services (beauty/make-up, retail and wholesale),
- Electrical,
- Business,
- Health, childcare, aged care, and education assistant.

The above information provides only an indication of the courses to be delivered and will depend upon skill shortages at the time and participating Registered Training Organisation's (RTO) ability to deliver.

Why apply for the Career Link Program?

- Students can undertake a taste of trades and other career paths within a desired industry whilst still completing their Western Australian Certificate of Education (WACE);
- The Career Link Program provides course equivalence towards a student's WACE;
- Assists students to make career decisions;
- Provides pathways to an apprenticeship and/or employment;
- Students receive credits for successful completion of a qualification; and

Who Can Apply?

Applications will be accepted from students who can meet the following criteria:

- Students MUST be accepted into the Career Link program at Mount Lawley Senior High School,
- Students MUST be commencing Year 11 or continuing 12 in 2027, there is some opportunities to commence as a Year 12 student,
- Students MUST pass or have passed Year 10 with a 'C' grade average (Year 10 mid-year report can be included for application purposes),
- Students MUST have support from the school including endorsement as "work ready".
- It is compulsory for schools to make comment on the application form of each student whether the application is supported or not. This will assist in the selection of students where interviews will not be undertaken,
- Students MUST meet Australian citizenship and visa requirements,
- Students MUST NOT have completed a Certificate II or higher in the qualification for which they are applying,
- Students must have an attendance of 87%.

How Do Students Apply for External Certificate Qualifications?

The Selection Process

- **Step 1:** All applications for the Career Link Program will be forwarded to TAFE by the Careers/VET Coordinator for assessment against above criteria.
- **Step 2:** Interviews may then be conducted, if deemed necessary, from the pool of students applying. These interviews will be arranged by the RTO and all information regarding an interview will be provided directly to the student where applicable.
- **Step 3:** Students will be advised during Term 4 of the outcome of their application.

Late Applications: Applications received after the TAFE deadline will be placed on a wait list in order of the date they are received. If a position becomes available in a class, applications will be taken from the waitlist and will go through the assessment process (interviews may be conducted). Applications will be taken from the wait list until all classes/programs are filled, this may well continue into 2027.

Charges: Secondary school students who are Australian citizens or permanent residents undertaking VET courses as part of their secondary education are exempt from tuition and enrolment charges, however, depending on the chosen industry may be required to purchase uniform, protective equipment, text books and trade equipment/tools.

**Fee-For-Service @ Private RTOs are full-fee.*

ABORIGINAL SCHOOL BASED TRAINEESHIPS

Aboriginal School Based Traineeships (ASBTs) provide the opportunity for Aboriginal and/or Torres Strait Islander students to start a traineeship whilst also completing the Western Australian Certificate of Education (WACE). Under these arrangements students are both a full-time student and a part-time employee, with the same employment and training responsibilities as other trainees.

In order to be an Aboriginal school based trainee a student must:

- be a full-time senior secondary school student in Years 11 or 12;
- enter into a Training Contract with an employer to complete a traineeship;
- have the school's agreement to undertake a school based traineeship;
- have the competencies achieved in the traineeship included in your WACE; and
- be 15 years of age at the date of commencement of the training contract.

Aboriginal School Based Traineeships undertake a Certificate II or higher in a chosen industry. Training on-the-job will be equivalent to a full day/shift in the workplace. Off-the-job training may also be taken at a Trade Training Centre of a State Training Provider.

There must be an average of 7.5 hours of paid work per week integrated over the period of the Training Contract, including school holidays. Students need to find an employer to offer a School Based Traineeship. SBT training will generally take one day per week in Year 11, and two days per week in Year 12. For the remaining three days students must attend school to complete School Curriculum and Standards Authority courses. Students must be accepted into the Career Link Program.

To obtain further information about these qualifications, please contact:

David Toothill | Program Coordinator - VET/Careers
david.toothill@education.wa.edu.au
9265 1532

UNIQUE STUDENT IDENTIFIER (USI)

It is compulsory for all students who undertake a Vocational Education and Training (VET) certificate course to create a Unique Student Identifier (USI) as a reference number. The USI will make it easier for students to record their VET achievements and ensure that students' VET records are not lost.

The USI is available online and at no cost to the student. This USI will stay with the student for life and be recorded with any nationally recognised VET course that is completed from when the USI legislation came into effect on 1 January 2015.

The USI is required by the School Curriculum and Standards Authority (SCASA) to allow VET certificate results to be counted towards the achievement of WACE, and will be a requirement of university graduation.

STEP 1: Go to <http://www.usi.gov.au> and create your Unique Student Identifier

This will only take a few minutes. When you have completed the process you will receive an email with your unique student identifier information.

STEP 2: Forward the official USI email to:

Senior School Administration Office
mountlawley.shs.seniorschooladmin@education.wa.edu.au

We will then add this number to your student record.

Please ensure that your **full name** and **year level** are included in the email.

We are taking a whole school approach to ensure that the USI is recorded on all Year 10 students' records and NO Year 11 Course Selection will be processed without the USI.

YEAR 11 and 12 Pathways

Course Information Handbook 2027

CAREER, TAFE & WA UNIVERSITY CONTACTS

Jobs & Skills Centre WA
www.jobsandskills.wa.gov.au
13 64 64

This centre aims to help in the transition from school into employment and training. Computer programs including JAC (Job and Course Explorer) are available to assist with career decision making and resume writing. A counselling service is also available.

Metropolitan TAFE Colleges
North Metropolitan TAFE
www.northmetrotafe.wa.edu.au

South Metropolitan TAFE
www.southmetrotafe.wa.edu.au

Tertiary Institutions Service Centre (TISC)
www.tisc.edu.au
(08) 9318 8000
info@tisc.edu.au
Level 1, 100 Royal Street, East Perth WA 6004
(9:00am - 4:30pm)

WA Universities
Curtin University
www.curtin.edu.au

Edith Cowan University (ECU)
www.ecu.edu.au

Murdoch University
www.murdoch.edu.au

Notre Dame University
www.nd.edu.au

University of Western Australia (UWA)
www.uwa.edu.au

ONLINE RESOURCES

There are a number of websites which provide useful information relating to career and study options.

Mount Lawley Senior High School Careers
careers.lawley.wa.edu.au

Department of Employment and Workplace Relations
dewr.gov.au
Information on employment and workplace relations.

myFuture
myfuture.edu.au
Occupations, demand, average weekly earnings, training, and funding.

The Good Universities Guide
gooduniversitiesguide.com.au
Comprehensive information about tertiary education pathways, and career options.

Jobs and Skills WA
jobsandskills.wa.gov.au
Provides course and jobs information.

Workforce Australia
workforceaustralia.gov.au
Search and apply for jobs or find more information on their pathway to employment.

Open Universities Australia
open.edu.au

Career One
careerone.com.au

Skillsroad
skillsroad.com.au
Start your career journey.



ARTS

ARTS

The following courses are on offer in The Arts learning area:

	Year 11 (Unit 1 & 2)	Code	Cost	Year 12 (Unit 3 & 4)	Code	Cost
VISUAL ARTS	General Courses					
	Visual Arts	GEVAR	\$150	Visual Arts	GTVAR	\$150
	ATAR Courses					
	Visual Arts	AEVAR	\$150	Visual Arts	ATVAR	\$150
DRAMA	General Courses					
	Drama	GEDRA	\$80	Drama	GTDR	\$80
	ATAR Courses					
	Drama	AEDRA	\$90	Drama	ATDR	\$90
	Certificate Qualifications (2 Year Delivery)					
	Year 11 Certificate II in Creative Industries CUA20225 (course begins)		\$185	Year 12 Certificate II in Creative Industries CUA20225 (course continues)		\$185
MEDIA PRODUCTION & ANALYSIS	General Courses					
	Media Production & Analysis	GEMPA	\$90	Media Production & Analysis	GTMPA	\$90
	ATAR Courses					
	Media Production & Analysis	AEMPA	\$90	Media Production & Analysis	ATMPA	\$90
	Certificate Qualifications (2 Year Delivery)					
	Year 11 Certificate II in Creative Industries (Media) CUA20225 (course begins)		\$185	Year 12 Certificate II in Creative Industries (Media) CUA20225 (course continues)		\$185
MUSIC	ATAR Courses					
	Music	AEMUS	\$90	Music	ATMUS	\$90
	PIMS					
	Jazz, Contemporary or Western Art Music	PIMS	\$50	Jazz, Contemporary or Western Art Music	PIMS	\$50
	Certificate Qualifications (2 Year Delivery)					
	Year 11 Certificate III in Music CUA30920 (course begins)		\$110	Year 12 Certificate III in Music CUA30920 (course continues)		\$110

* Costs are estimates and are subject to change.

YEAR 11 and 12 Pathways

Course Information Handbook 2027

VISUAL ARTS

Students selecting Visual Arts engage in practical learning activities across various studio areas.

The General and ATAR Visual Arts courses are designed to maximise opportunities for understanding studio materials while exploring creative outcomes. Students develop ideas, experiment with media, and apply visual research to produce artworks for display and/or external marking.

Throughout the course, students build skills and confidence in a range of studio areas, including illustration, sketching, digital painting, traditional painting, printmaking, ceramics, sculpture, and more. They are required to maintain a portfolio that documents their design process and visual thinking, which can be used for entry into some university or TAFE courses.

Students are guided to create independent artworks that demonstrate technical skill and a personal creative style. All artistic projects are expected to be completed to a display-ready standard. Visual Arts requires students to demonstrate organisation and self-management. They are expected to develop problem-solving skills and make independent artistic choices through creative exploration and analytical thinking.

These courses encourage and engage students in developing expressive artworks that show increasing levels of sophistication, skill, innovation and complexity.

VISUAL ARTS GENERAL COURSE

Prerequisites

None

Classwork/Theory 30%

Practical/Production 70%

Year 11 GEVAR

The Year 11 General Visual Arts course offers an introduction to art, craft and design. Students are guided through the design process to create artworks for presentation. They explore drawing and design steps, demonstrating a fundamental understanding of art language and an appreciation of the visual arts.

This practical course allows students to explore creativity using a range of materials and studio techniques. Independent exploration of ideas is encouraged, enabling students to develop confidence in creating artwork for final display.

Students produce a portfolio that documents their design process, which can be used for entry into creative courses and further studios. While projects and outcomes are primarily guided by teacher, students are given opportunities to develop their own creative abilities.

UNIT 1– EXPERIENCES

The focus of this unit is on developing design ideas and following steps to produce concepts for final artwork. Students use simple techniques and processes to develop their observational skills and design sensibilities. The unit culminates in at least one resolved artwork that demonstrates application of care in the use of materials.

UNIT 2 – EXPLORATIONS

This unit consolidates the processes used to make visual art using selected materials and techniques. Students use visual influences and undertake research to further develop their ideas and design solutions. The focus of the unit is on consolidating the design process to resolve artwork to display standard.

YEAR 11 and 12 Pathways

Course Information Handbook 2027

Year 12 GTVAR

The Year 12 General Visual Arts course expands student's capacity to develop and use a range of materials, techniques and processes. Students are encouraged to develop original ideas using art language while appreciating other art forms and practices. This practical course allows students to employ various studio techniques and creative approaches to making original artwork. They investigate the work of selected artists, producing artwork through inquiry, research, and design development.

UNIT 3 – INSPIRATIONS

Students produce artworks that relate to each other creating cohesion and a sense of personal artistic style. Students gain inspiration and generate ideas from diverse sources, including traditional and contemporary artists. The breath of the inquiry allows for personal choice of selecting materials and techniques that are best related to student interest.

UNIT 4 – INVESTIGATIONS

Students refine the selection of artistic influences to further develop ideas that best match their skills and abilities. Students are encouraged to research artists that expand their skills and challenge their artistic sensibilities.

VISUAL ARTS ATAR COURSE**Prerequisites**

Grade B in Year 9/10 Visual Arts and a recommendation in ATAR English.

Classwork/Theory 30%

Practical/Production 70%

Year 11 AEVAR

The Year 11 ATAR Visual Arts course is focused on the exploring personal ideas and expanding skills that will lead to the creation of high-quality artwork for exhibition and display. Students select visual influences and research artists to inform the development of their own ideas. They explore and experiment with materials and techniques to find solutions to ideas and concepts that will form the compositions of final artworks.

Students create body of resolved artwork for exhibition and document their thinking and working practices as professional portfolio that can be used for competitive entry into courses at TAFE or university. Students are given maximum opportunity to develop their own artistic style and project directions.

UNIT 1 – DIFFERENCES

Students explore their own ideas and develop a personal direction for their artistic journey. They select artistic influences relevant to their own personal themes. The emphasis of this unit is to inform ideas and develop approaches that support their own personal artistic style and direction.

This focus of this unit is to create a portfolio that documents the development of thinking and working practices that lead towards the creation of personally, expressive and socially relevant artwork. At the end of this unit students will have:

- Researched and selected visual influences to support the development of their own ideas
- Created drawings and represented their ideas through experimentation and materials manipulation
- Explained the intentions of their work by writing a 300 word artist statement
- Presented a portfolio that shows their skill in the use of media, techniques and processes which will be used to produce their final artwork.

YEAR 11 and 12 Pathways

Course Information Handbook 2027

UNIT 2 – IDENTITIES

Students focus on producing final artwork for display. They decide on the materials and techniques they will use and create resolved artwork that demonstrates their selective use of materials, techniques and processes.

- The focus of this unit is to create a final (resolved) artwork which shows considered use of materials, techniques and processes. At the end of this unit students will have:
- Refined their ideas and developed their concept for the production of final artwork
- Used their class time effectively to produce final artwork that shows problem solving, innovation and skill in the use of materials to execute their ideas.
- Created a composition that shows understanding of art language and design principles to support the production of their body of work.

Year 12 ATVAR

Year 12 ATAR Visual Arts is focused on the execution high quality artwork for external marking and competitive entry into state-wide exhibitions and tertiary entry courses.

Students are asked to focus on their area of personal strength and interest to produce resolved artwork/s that shows their full artistic skill and potential.

Students may create work in any medium of choice and are encouraged to explore a combination of 2D, 3D and digital approaches which best suit their skills, ideas and artistic directions. Innovation and personal solutions are encouraged. In their final year of ATAR Visual Arts studies students are expected to resolve and produce final artworks that are 'display ready' supported by an artist statement explaining their ideas, intentions and artistic journey.

UNIT 3 – COMMENTARIES

The refinement of personal themes and artistic directions are considered in relation to the significance of our contemporary society. Students clarify their ideas and intentions in their artist statement to make comment or explain their point of view. They use materials and media that best enhance the communication of their ideas and personal artistic intentions. At the end of this unit students will have:

- Refined their ideas and developed their concept for the production of final artwork
- Used their class time effectively to produce final artwork that shows problem solving, innovation and skill in the use of materials to execute their ideas.
- Created a composition that shows understanding of art language and design principles to support the production of their body of work.

UNIT 4 – POINTS OF VIEW

The course culminates in the completion of resolved artwork/s that demonstrates the student's technical and artistic abilities for external assessment. Resolved artwork may be created in 2D, 3D or digital moving imagery and is supported by an artist statement that explains the ideas and artistic approach taken. At the end of this unit students will have:

- Refined their ideas and developed their concept for the production of final artwork
- Used their class time effectively to produce final artwork that shows problem solving, innovation and skill in the use of materials to execute their ideas.
- Created a composition that shows understanding of art language and design principles to support the production of their body of work.

DRAMA

Drama is a dynamic and timeless art form, woven into everyday life. In this course, you'll dive into aesthetic understanding and hands-on practice, using drama's elements and conventions to craft original performances and bring texts to life.

Beyond acting, you'll explore the principles of Theatre design with specific focus on set, lighting and sound design. You'll perform for different audiences and adapt to various settings. Collaboration is key!

You'll sharpen time management, leadership, and problem-solving skills while thinking creatively and analytically. Importantly, Drama Students engage with the human experience, building empathy, emotional intelligence, and deeper connections through creative exploration. From Australian stories to global theatre, Drama lets you express, explore, and evolve.

DRAMA GENERAL COURSE

Prerequisites

None

Year 11 GEDRA

UNIT 1 – DRAMATIC STORYTELLING

The focus of this unit is dramatic storytelling. Students engage with the skills, techniques, processes and conventions of dramatic storytelling. Students view, read and explore relevant drama works and texts using scripts and/or script excerpts from Australian and/or world sources.

UNIT 2 – DRAMA PERFORMANCE EVENTS

The focus for this unit is drama performance events for an audience other than their class members. In participating in a drama performance event, students work independently and in teams. They apply the creative process of devising and of interpreting Australian and/or world sources to produce drama that is collaborative and makes meaning.

Year 12 GTDRA

UNIT 3 – REPRESENTATIONAL, REALIST DRAMA

The focus for this unit is representational, realist drama. Students explore techniques of characterisation through different approaches to group based text interpretation, particularly those based on the work of Stanislavski and others. In this unit, students have the opportunity to research and collaboratively workshop, interpret, perform and produce texts in forms and styles related to representational, realistic drama that educate and present perspectives.

UNIT 4 – PRESENTATIONAL, NON-REALIST DRAMA

The focus of this unit is presentational, non-realist drama. Students explore techniques of role and/or character through different approaches to group based text interpretation, particularly those based on the work of Brecht and others. In this unit, students have the opportunity to research and collaboratively workshop, interpret and perform drama texts related to presentational, non-realistic drama that challenge and question perspectives.

DRAMA ATAR COURSE

Prerequisites

B grade in Year 9/10 Visual Arts and a recommendation in ATAR English.

Classwork/Theory – 50%

Practical/Production – 50%

Year 11 AEDRA

UNIT 1 – REPRESENTATIONAL, REALIST DRAMA

The focus for this unit is representational, realist drama. Students explore techniques of characterisation through different approaches to group based text interpretation, particularly those based on the work of Stanislavski and others. In this unit, students have the opportunity to research and collaboratively workshop, interpret, perform and produce texts in forms and styles related to representational, realistic drama that educate and present perspectives.

UNIT 2 – PRESENTATIONAL, NON-REALIST DRAMA

The focus of this unit is presentational, non-realist drama. Students explore techniques of role and/or character through different approaches to group based text interpretation, particularly those based on the work of Brecht and others.

In this unit, students have the opportunity to research and collaboratively workshop, interpret and perform drama texts related to presentational, non realistic drama that challenge and question perspectives.

Year 12 ATDRA

The focus for this unit is to reinterpret dramatic text, context, forms and styles for contemporary audiences through applying theoretical and practitioner approaches. This includes physical theatre approaches, such as Jacques Lecoq, Anne Bogart and Tadashi Suzuki and text – based approaches, such as Theatre of the Absurd, Asian theatre and Poor Theatre. In this unit, students work on the reinterpretation of text, subtext, context, form and style through in depth study.

MEDIA PRODUCTION & ANALYSIS

The Media Production and Analysis course aims to prepare students for a future in a digital and interconnected world by providing the skills, knowledge and understandings to tell their own stories and interpret the stories of others. Students are encouraged to explore, experiment and interpret their world, reflecting and analysing contemporary life, while understanding that this is done under social, cultural and institutional constraints. Students, as users and creators of media products, consider the important role of audiences and their context.

In all courses of Media Production and Analysis, students will be required to make media products. The production of media work enables students to demonstrate their understanding of the key concepts of media languages, representation, audience, production, skills and processes as well as express their creativity and originality. When producing media work, students learn to make decisions about all aspects of production, including creative choices across pre-production, production and post-production phases. This provides an opportunity for students to reflect on and discuss their own creative work, intentions and outcomes.

Within this process, skills are developed enabling students to manipulate technologies which simulate industry experiences.

MEDIA PRODUCTION & ANALYSIS GENERAL COURSE

Prerequisites

B grade in Year 9 or 10 to do Year 11

B grade in Year 11 to do Year 12

General courses of Media Production and Analysis are suitable for students with an interest in producing audio visual productions and the underpinning theories that make them successful. This course is also well suited for students interested in continuing their study of media through vocational education or wish to enter the workplace in this area.

Students should be aware that this is a highly practical course with a focus on collaborative work and a flexible approach to learning is required. Students gain skills in script writing, cinematography, editing, sound design and special effects, while also learning to become effective team members. Students will develop their knowledge and skills by being involved in long term projects and will be assessed using various methods – production, response, performance and, in Year 12, an externally set written task. This course is organised into a Year 11 syllabus and a Year 12 syllabus. The complexity of the syllabus content increases from Year 11 to Year 12. The Year 11 syllabus (GEMPA) is divided into two units, each of one semester duration, which are typically delivered as a pair. Similarly, the Year 12 syllabus (GTMPA) is organised in this manner.

Year 11 GEMPA

UNIT 1– MASS MEDIA

The focus of this course is Mass Media – students reflect on their own use of media in an ever-changing world, and how they as both consumers and producers of media, can make a positive impact. One of our focuses are gaming and social media – we examine the history of each and look at how it has developed alongside technological advancement. Students are introduced to representation and theories, learning how codes and conventions are used to construct specific representations across a range of genres and platforms. Students will have the opportunity to analyse and pitch original game design as well as comment on the future direction of both social media and gaming, and the impacts on audiences through a range of production tasks. Students analyse, view, listen and interact with a range of media works during the course allowing them to generate ideas and apply their knowledge and creativity in production.

YEAR 11 and 12 Pathways

Course Information Handbook 2027

UNIT 2 – POINT OF VIEW

The focus of this course is to look at how audiences are or can be manipulated to accept or challenge a range of views presented to us through the mainstream media. One of our focuses is the examination of the rise of the reality television genre, and the use of codes and conventions that manipulate audiences as well as focussing on students' understanding of what is 'real' when it comes to media. Students will view a range of programming, both commercial and non-commercial, and analyse the codes and conventions that are utilised to manipulate point of view. Students will have the opportunity to create their own media works and utilise production processes which reflect their understanding of this genre and the techniques associated with the creation of representation. We also examine the role of 'Grindhouse' film posters, their historical significance, and the way film advertising has progressed into a digital world – students are asked to question if advertising in print form is still relevant? This will allow for a link to our future study of Unit 3 in Year 12. Students analyse, view, listen and interact with a range of media works during the course allowing them to generate ideas and apply their knowledge and creativity in production.

Year 12 GTMPA

UNIT 3 – ENTERTAINMENT

The focus of this course is entertainment in a contemporary world. Students will expand on their understanding of how the media works through the review of media language and the associated codes and conventions. One focus will be the study of film – short film as well as alternative long form cinema – as we examine entertainment in the era of streaming platforms and access to a multitude of production types and distribution. Students will analyse how the viewing and production of media works have changed and developed as technology changes. Students will produce a narrative short film of their own devising, specialising in a key technical role. Throughout the unit students will analyse, view and interact with contemporary and relevant media work which will allow them to generate ideas and learn production skills and processes as they apply their knowledge and creativity in production.

UNIT 4 – REPRESENTATION AND REALITY

The focus for this course centres around the way Media works construct representation and narrative. Students will consider different types of representations, particularly those constructed online, and how they relate to how an audience reads a range of Media works. One focus will be the study of the concept of 'celebrity' and how producers of media work present 'celebrities' in the modern context of social media and the 24/7 news cycle. Students will choose from a range of media genres and styles and examine ways in which codes, conventions and techniques are used to dramatize and represent reality and engage audiences for profit. This focus will be carried through to the analysis of the documentary genre where an individual is the focus of the narrative structure. In contexts related to representation and reality, students analyse, view and produce a variety of media work while learning about production controls and constraints in the contemporary delivery of media across platforms.

MEDIA PRODUCTION & ANALYSIS ATAR COURSE

Prerequisites

B grade in Year 9/10 Media and a minimum of a B grade in English. Students must be recommended for ATAR English.

Classwork/Theory – 50%

Practical/Production – 50%

These ATAR courses of Media Production and Analysis have been developed for students who wish to continue their interest in this course and who are University bound. Students should be aware that this course is very busy and a flexible approach to learning is required. It is expected that students complete many aspects of the course outside of class contact time. In particular, students are required to do significant amounts of their filming and taping off campus and outside of school hours. Students will develop their knowledge and skills by being involved in long term projects and will be assessed using various methods – response, production, performance and examinations. This course is organised into a Year 11 syllabus (AEMPA) and a Year 12 syllabus (ATMPA). The cognitive complexity of the syllabus content increases from Year 11 to Year 12.

YEAR 11 and 12 Pathways

Course Information Handbook 2027

Year 11 AEMPA**UNIT 1 – POPULAR CULTURE**

The focus for this course is popular culture. This focus involves identifying what is meant by ‘popular’ culture and considering the types of media, ideas and audiences from which popular culture evolves. Students analyse, view, listen to and interact with a range of popular media, develop their own ideas, learn production skills and apply their understandings and skills in creating their own productions. There are many aspects of popular culture that can be used to provide students with interesting and relevant learning contexts, and an opportunity to explore how audiences consume popular media. Teachers should select learning contexts that are familiar to students or provide stimulation and new experiences. In contexts related to popular culture, students have the opportunity to explore a variety of popular media work, and learn how to interpret the meanings created by codes and conventions.

Students develop production and analytical skills and apply their understanding of media languages and audiences while learning about and working in specific production contexts.

UNIT 2 – INFLUENCE

The focus for this course is the influence of media. Students analyse and respond to a range of media work designed to influence audience. Students develop their own ideas and expand production skills to produce media work in the context of media influence. In contexts related to journalism and other influential media, students analyse and respond to media designed to influence audiences. They undertake more extensive research into the representation of groups and reporting of issues within media work. Students apply their understanding of media influence to extend their production skills and to communicate ideas by producing short documentary films. They work to become increasingly independent as they operate technologies and use techniques to express ideas in their productions.

Year 12 ATMPA**Prerequisites**

Typically for students who have highly proficient knowledge, skills and understandings in Media Studies or have completed the Year 11 ATAR MPA course (AEMPA) and achieved at least a ‘C’ Grade.

Classwork/Theory – 50%

Practical/Production – 50%

UNIT 3 – MEDIA ART

The focus for this course is media art forms. This unit provides the opportunity for students to explore and select from a range of media art and develop their understanding of media aesthetics. Media aesthetics in the context of this unit is the study of the emotional and intellectual response brought about by the way the techniques, codes and conventions that create the artistic quality of the media work have been applied.

Students analyse, view, listen to and interact with contemporary and traditional examples of media art, identifying techniques and themes, meanings that are created and audiences’ interpretations. They consider the representation of values and technological developments that influence perceptions of art within media work. Students are encouraged to experiment with technologies, structures, codes and conventions to express their ideas and creativity. They have the opportunity to extend their production skills and processes and the emergence of personal style.

UNIT 4 – POWER AND PERSUASION

The focus for this unit is power and persuasion, which includes the influential nature of media used as a form of propaganda and political persuasion. Through this broad focus, students extend their understanding of persuasive media, examining the way the media is able to reflect, challenge and shape values and attitudes. They critically analyse, view, listen to, and interact with a range of media work, considering the purposes and values of producers and audiences. Students synthesise a range of ideas, skills and processes to create their own media productions that express their views.

YEAR 11 and 12 Pathways

Course Information Handbook 2027

MUSIC

There are three types of music courses to choose from in Years 11 and 12.

Students may choose:

1. ATAR Music in Years 11 and 12 (recommended for university entrance)
2. PIMS Course in Years 11 and 12 (Instrumental and Ensemble only)
3. Certificate III in Music

Students can elect to choose both ATAR Music and Certificate III in Music.

MUSIC ATAR COURSE

Prerequisites

Students must have completed any one of the following:

- **A minimum B grade in Year 10 Class Music and Instrumental Music; and a passed Grade 3 AMEB Theory Exam and Practical Exam; or**
- **The equivalent overseas or interstate qualifications.**

Classwork/Theory – 50%

Practical/Production – 50%

Music is more than sound - it's expression, emotion, and identity. In the ATAR Music Course, you'll perform, compose, analyse, and build confidence while sharpening creativity and collaboration. Tailor your learning by selecting to specialise in performing in the music genre that you are most passionate about.

Explore music across time, cultures, and styles while developing resilience and problem-solving skills. This course opens doors to careers in performance, production, and education. Students continuing their music education in PIMS; Certificate III Music Industry or ATAR can use examples from the ensemble program as evidence of their leadership and community service for their university entrance.

Students may choose between a performance or composition focus. The classwork component focuses on the history, theory, and aural aspects of Jazz, Western Art, and Contemporary genres. The course requires a significant commitment of extracurricular hours.

Year 11 AEMUS

UNIT 1 – ELEMENTS

What are the building blocks that make music work? Students respond to music as they explore the creative application of music elements across time, place and culture. They gain greater familiarity with how and why music is created, by engaging with a range of designated works, developing their understanding and use of music elements.

UNIT 2 – NARRATIVES

How can music tell a story? Students understand that music elements can be manipulated to expressively communicate narrative. Through the combination of music and narrative, composers can provoke strong emotional responses from audiences. This unit aims to develop a more sophisticated understanding of how music elements have been manipulated for specific storytelling purposes.

Students apply critical listening and thinking skills and develop aesthetic understanding through analysing the designated works.

YEAR 11 and 12 Pathways

Course Information Handbook 2027

Year 12 ATMUS**UNIT 3 – IDENTITIES**

What can music tell us about people? Through the journey of critically considering how music can be used as a powerful form of expression, students explore the potential for music to communicate identity.

UNIT 4 – INNOVATIONS

What drives a composer to create something truly different? Innovation within music is a result of ideas driven by personal experience, and socio-political and cultural influences.

ALL GENRES (CONTEMPORARY, CLASSICAL AND JAZZ)**PIMS**

This course is for students wishing to continue the practical aspects of music. It requires students to partake in a weekly instrumental lesson and attend a minimum of one ensemble session per week. The course is assessed on a pass/fail basis.



ENGLISH

ENGLISH

Students are required to complete 4 units of English or Literature over 2 years. This is a compulsory requirement for all students.

General Courses					
Year 11 (Unit 1 & 2)	Code	Cost	Year 12 (Unit 3 & 4)	Code	Cost
English	GEENG	\$64	English	GTENG	\$64
English as an Additional Language or Dialect	GEELD	\$64	English as an Additional Language or Dialect	GTELD	\$64
ATAR Courses					
Year 11 (Unit 1 & 2)	Code	Cost	Year 12 (Unit 3 & 4)	Code	Cost
English	AEENG	\$64	English	ATENG	\$64
Literature	AELIT	\$64	Literature	ATLIT	\$64
English as an Additional Language or Dialect	AEELD	\$60	English as an Additional Language or Dialect	ATELD	\$60

NOTE: Students can select both English ATAR and Literature ATAR.

*** Costs are estimates and are subject to change.**

ENGLISH GENERAL COURSE

Prerequisites

None

The English General course focuses on consolidating and refining the skills and knowledge needed by students to become competent, confident and engaged users of English in everyday, community, social, further education, training and workplace contexts.

The English General course is designed to provide students with the skills that will empower them to succeed in a wide range of post secondary pathways.

The course develops students' language, literacy and literary skills to enable them to communicate successfully both orally and in writing and to enjoy and value using language for both imaginative and practical purposes.

Students comprehend, analyse, interpret and evaluate the content, structure and style of a wide variety of oral, written, multimodal, digital and media texts. Students learn how the interaction of structure, language, audience and context helps to shape how the audience makes meaning. Both independently and collaboratively, they apply their knowledge to create analytical, imaginative, interpretive and persuasive texts in different modes and media.

Year 11 GEENG

UNIT 1

Focuses on students comprehending and responding to the ideas and information presented in texts.

Students:

- employ a variety of strategies to assist comprehension;
- read, view and listen to texts to connect, interpret and visualise ideas;

YEAR 11 and 12 Pathways

Course Information Handbook 2027

- learn how to respond personally and logically to texts by questioning, using inferential reasoning and determining the importance of content and structure;
- consider how organisational features of texts help the audience to understand the text;
- learn to interact with others in a range of contexts, including everyday, community, social, further education, training and workplace contexts;
- communicate ideas and information clearly and correctly in a range of contexts; and
- apply their understanding of language through the creation of texts for different purposes.

UNIT 2

Focuses on interpreting ideas and arguments in a range of texts and contexts.

Students:

- analyse text structures and language features and identify the ideas, arguments and values expressed;
- consider the purposes and possible audiences of texts;
- examine the connections between purpose and structure and how a text's meaning is influenced by the context in which it is created and received;
- integrate relevant information and ideas from texts to develop their own interpretations;
- learn to interact effectively in a range of contexts; and
- create texts using persuasive, visual and literary techniques to engage audiences in a range of modes and media.

Year 12 GTENG

UNIT 3

Focuses on exploring different viewpoints presented in a range of texts and contexts.

Students:

- explore attitudes, text structures and language features to understand a text's meaning and purpose;
- examine relationships between context, purpose and audience in different language mode and types of texts, and their impact on meaning;
- consider how perspectives and values are presented in texts to influence specific audiences;
- develop and justify their own interpretations when responding to texts; and
- learn how to communicate logically, persuasively and imaginatively in different context for different purposes, using a variety of types of texts.

UNIT 4

Focuses on community, local or global issues and ideas presented in texts and on developing students' reasoned responses to them.

Students:

- explore how ideas, attitudes and values are presented by synthesising information from a range of sources to develop independent perspectives;
- analyse the ways in which authors influence and position audiences;
- investigate differing perspectives and develop reasoned responses to these in a range of text forms for a variety of audiences;
- construct and clearly express coherent, logical and sustained arguments and demonstrate an understanding of purpose, audience and context; and
- consider intended purpose and audience response when creating their own persuasive, analytical, imaginative, and interpretive texts.

ENGLISH AS AN ADDITIONAL LANGUAGE OR DIALECT GENERAL COURSE

Prerequisites

None

The English as an Additional Language or Dialect (EAL/D) General course focuses on language learning and the explicit teaching of the structure, linguistic features and sociolinguistic and sociocultural aspects of Standard Australian English (SAE). Through close study of language and meaning, students of the English as an Additional Language General course explore how learning in and through English language and literature influences their own and others' personal, social and cultural identities and thought processes.

They develop skills that enable them to use different registers of spoken and written SAE so they can communicate effectively in a range of contexts and for a variety of purposes in order to become effective cross cultural users of language and dialect.

The English as an Additional Language or Dialect General course provides opportunities for students to engage reflectively and critically with a broad range of spoken, written and multimodal texts, including literary and non-literary texts, for example, academic, everyday and workplace texts. Students learn to create, individually and collaboratively, increasingly complex texts for different purposes and audiences in different forms, modes and media.

Year 11 GEELD

UNIT 1

Unit 1 focuses on responding to and creating extended texts in familiar contexts in SAE. By using the language modes, students engage with familiar and some unfamiliar texts, including literary texts. Language skills for effective communication in SAE in most social, familiar and some community situations are developed. The unit will enable students to create extended oral, written and multimodal texts with a degree of accuracy in structure, language and register. Strategies for collecting, organising and presenting ideas and information continue to be developed.

UNIT 2

Unit 2 focuses on responding to and creating connected extended texts in personal, social, community and workplace contexts in SAE. The ability to use SAE language skills to communicate for a range of purposes is evident in the creation of oral, written and multimodal texts required in the workplace and some academic contexts. Some cultural assumptions are explored and explained through the study of a variety of texts, including popular and literary texts. Strategies for collecting, organising and presenting ideas and information are consolidated.

Year 12 GTELD

UNIT 3

Unit 3 focuses on investigating how language and culture are interrelated and expressed in a range of contexts. A variety of oral, written and multimodal texts are used to develop understanding of text structures and language features. The relationship between these structures and features and the context, purpose and audience of texts is explored. The unit will enhance students' confidence in creating texts for different purposes and across all language modes in both real and imagined contexts. It will broaden their understanding of the sociocultural and sociolinguistic elements of SAE and develop skills for work and further study.

UNIT 4

Unit 4 focuses on analysing and evaluating perspectives and attitudes presented in texts and creating extended texts for a range of contexts. SAE language skills for effective communication in an expanding range of contexts are consolidated. The use of cohesive text structures and language features is developed. The unit focuses on developing planning and editing skills to create extended oral, written and multimodal texts. Attitudes, values and culturally based assumptions within texts are identified, analysed and compared. Strategies for collecting, analysing, organising and presenting ideas and information are refined.

YEAR 11 and 12 Pathways

Course Information Handbook 2027

ENGLISH ATAR COURSE

Prerequisites

Year 10 course mark – 60% or higher, Year 10 (Semester 1) exam mark – 60% or higher.

The English ATAR course focuses on developing students' analytical, creative, and critical thinking and communication skills in all language modes. It encourages students to critically engage with texts from their contemporary world, with texts from the past and with texts from Australian and other cultures. Such engagement helps students develop a sense of themselves, their world and their place in it.

Through close study and wide reading, viewing and listening, students develop the ability to analyse and evaluate the purpose, stylistic qualities and conventions of texts and enjoy creating their own imaginative, interpretive, persuasive and analytical responses. The English ATAR course is designed to develop students' facility with all types of texts and language modes and to foster an appreciation of the value of English for lifelong learning. Students refine their skills across all language modes by engaging critically and creatively with texts. They learn to speak and write fluently in a range of contexts and to create a range of text forms. They hone their oral communication skills through discussion, debate and argument, in a range of formal and informal situations.

Year 11 AEENG

UNIT 1

Students explore how meaning is communicated through the relationships between language, text, purpose, context and audience. This includes how language and texts are shaped by their purpose, the audiences for whom they are intended and the contexts in which they are created and received. Through responding to and creating texts, students consider how language, structure and conventions operate in a variety of imaginative, interpretive and persuasive texts. Study in this unit focuses on the similarities and differences between texts and how visual elements combine with spoken and written elements to create meaning. Students develop an understanding of stylistic features and apply skills of analysis and creativity. They are able to respond to texts in a variety of ways, creating their own texts and reflecting on their own learning.

UNIT 2

Students analyse the representation of ideas, attitudes and voices in texts to consider how texts represent the world and human experience. Analysis of how language and structural choices shape perspectives in and for a range of contexts is central to this unit. By responding to and creating texts in different modes and media, students consider the interplay of imaginative, interpretive and persuasive elements in a range of texts and present their own analyses. Students critically examine the effect of stylistic choices and the ways in which these choices position audiences for particular purposes, revealing and/or shaping attitudes, values and perspectives. Through the creation of their own texts, students are encouraged to reflect on their language choices and consider why they have represented ideas in particular ways.

Year 12 ATENG

UNIT 3

Students explore representations of themes, issues, ideas and concepts through a comparison of texts. They analyse and compare the relationships between language, genre and contexts, comparing texts within and/or across different genres and modes. Students recognise and analyse the conventions of genre in texts and consider how those conventions may assist interpretation. Students compare and evaluate the effect of different media, forms and modes on the structure of texts and how audiences respond to them. Understanding of these concepts is demonstrated through the creation of imaginative, interpretive, persuasive and analytical responses.

UNIT 4

Students examine different interpretations and perspectives to develop further their knowledge and analysis of purpose and style. They challenge perspectives, values and attitudes in texts, developing and testing their own interpretations through debate and argument. Through close study of texts, students explore relationships between content and structure, voice and perspectives and the text and context. This provides the opportunity for students to extend their experience of language and of texts and explore their ideas through their own reading and viewing. Students demonstrate understanding of the texts studied through creation of imaginative, interpretive, persuasive and analytical responses.

YEAR 11 and 12 Pathways

Course Information Handbook 2027

LITERATURE ATAR COURSE

Prerequisites

Year 10 course mark – 70% or higher, Year 10 (Semester 1) exam mark – 70% or higher.

The Literature ATAR course focuses on the study of literary texts and developing students as independent, innovative and creative learners and thinkers who appreciate the aesthetic use of language; evaluate perspectives and evidence; and challenge ideas and interpretations. The Literature ATAR course explores how literary texts construct representations, shape perceptions of the world and enable us to enter other worlds of the imagination. In this course, students actively participate in the dialogue of literary analysis and the creation of imaginative and analytical texts in a range of modes, media and forms.

Students enjoy and respond creatively and critically to literary texts drawn from the past and present and from Australian and other cultures. They reflect on what these texts offer them as individuals, as members of Australian society and as world citizens.

Students establish and articulate their views through creative response and logical argument. They reflect on qualities of literary texts, appreciate the power of language and inquire into the relationships between texts, authors, readers, audiences and contexts as they explore ideas, concepts, attitudes and values.

Year 11 AELIT

UNIT 1

Unit 1 develops students' knowledge and understanding of different ways of reading and creating literary texts drawn from a widening range of historical, social, cultural and personal contexts. Students analyse the relationships between language, text, contexts, individual points of view and the reader's response. This unit develops knowledge and understanding of different literary conventions and storytelling traditions and their relationships with audiences. A range of literary forms is considered: prose fiction, poetry and drama. The significance of ideas and the distinctive qualities of texts are analysed through detailed textual study. Through the creation of analytical responses, students frame consistent arguments that are substantiated by relevant evidence. In the creation of imaginative texts, students explore and experiment with aspects of style and form.

UNIT 2

Unit 2 develops students' knowledge and understanding of intertextuality, the ways literary texts connect with each other. Drawing on a range of language and literary experiences, students consider the relationships between texts, genres, authors, readers, audiences and contexts. The ideas, language and structure of different texts are compared and contrasted. Exploring connections between texts involves analysing their similarities and differences through an analysis of the ideas, language used and forms of texts. Students create analytical responses that are evidence-based and convincing. By experimenting with text structures and language features, students understand how their imaginative texts are informed by analytical responses.

Year 12 ATLIT

UNIT 3

Unit 3 develops students' knowledge and understanding of the relationship between language, culture and identity in literary texts. Students inquire into the power of language to represent ideas, events and people, comparing these across a range of texts, contexts, modes and forms. Through critical analysis and evaluation, the values and attitudes represented in and through texts and their impact on the reader are examined. Throughout the unit, students create analytical responses that are characterised by a confident, engaging style and informed observation. In creating imaginative texts, students experiment with language, adapt forms, and challenge conventions and ideas.

UNIT 4

Unit 4 develops students' appreciation of the significance of literary study through close critical analysis of literary texts drawn from a range of forms, genres and styles. Students reflect upon the creative use of language, and the structural and stylistic features that shape meaning and influence response. The unit focuses on the dynamic nature of literary interpretation and considers the insights texts offer, their use of literary conventions and aesthetic appeal. Students' analytical responses demonstrate increasing independence in interpreting texts and synthesising a range of perspectives into critical and imaginative responses. In creating imaginative texts, students experiment with literary conventions and reflect on how the created text takes into account the expectations of audiences.

YEAR 11 and 12 Pathways

Course Information Handbook 2027

ENGLISH AS AN ADDITIONAL LANGUAGE OR DIALECT ATAR COURSE

Prerequisites

Students must meet SCSA eligibility requirements to be in these courses.

The English as an Additional Language or Dialect (EAL/D) ATAR course focuses on language learning.

Year 11 AEELD

UNIT 1

Unit 1 focuses on investigating how language and culture are interrelated and expressed in a range of contexts. A variety of oral, written and multimodal texts are used to develop understanding of text structures and language features. Students explore the relationship between these structures and features and the context, purpose and audience of texts. The unit will enhance students' confidence in creating texts for different purposes and across all language modes in both real and imagined contexts. It will broaden their understanding of the sociocultural and sociolinguistic elements of SAE and develop skills for research and further academic study.

The thematic focus for this unit is ways of life. Using knowledge and skills from their existing languages and cultures, students learn to use English to explore wider social contexts beyond the personal and immediate community. From their position as cross-cultural learners, they examine issues and different points of views to develop, present and express ideas and opinions in relation to these. Through the investigation of a range of topics, students explore their relationships with cultures, deepen their understanding of cultural similarities, differences and values to develop their ability to use English. Students apply their SAE skills to examine the ways language is used in relation to these topics to position the viewer and reader.

UNIT 2

Unit 2 focuses on analysing and evaluating perspectives and attitudes presented in texts, and creating extended texts for a range of contexts. SAE language skills for effective communication in an expanding range of contexts are consolidated. The use of cohesive text structures and language features is developed. The unit focuses on developing planning and editing skills to create extended oral, written and multimodal texts. Attitudes, values and culturally based assumptions within texts are identified, analysed and compared. Strategies for collecting, analysing, organising and presenting ideas and information are refined.

The thematic focus for this unit is making choices. Using knowledge and skills from their existing languages and cultures, students learn to use English to identify and examine choices facing themselves, their families, communities and societies in relation to issues of concern presented in a range of texts. They examine and use the ways language can be used to analyse choices, influence attitudes and effect change.

Year 12 ATELD

UNIT 3

Unit 3 focuses on analysing how language choices are used to achieve different purposes and effects in a range of contexts. SAE language skills are developed so that they can be used to describe, inform, express a point of view and persuade for different purposes and audiences. The ways in which language choices shape meaning and influence audiences are explored through the study and creation of a range of oral, written and multimodal texts.

(continued from previous page)

The representation of ideas, attitudes and values and how these vary across cultures and within different contexts, particularly the Australian context, is analysed and evaluated. Effective and independent research skills are consolidated throughout the unit.

The thematic focus for Unit 3 is Australia as a cultural community. Using knowledge and skills from their existing languages and cultures, students learn to use English to further explore the concept of 'cultural schemas' and how culture influences the way in which they and other people view the world. Through the exploration of Australia as a multicultural society protecting individual freedoms, they develop an appreciation of the concept of cultural constructs. They also develop their ability to use English appropriate to audience and purpose. Their intercultural understandings enable them to apply analytical and problem-solving skills to their investigations of commonality and difference. Students use SAE to explore how structures, patterns and audience expectations influence language and meaning and that meaning is negotiated, not given, within and across cultures.

YEAR 11 and 12 Pathways

Course Information Handbook 2027

UNIT 4

Unit 4 focuses on analysing, evaluating and using language to represent and respond to issues, ideas and attitudes in a range of contexts. By extending and consolidating language and communication skills, critical use of SAE for a range of contexts, purposes and audiences is developed. Independent and collaborative investigation and analysis are used to explore how language and texts achieve specific purposes and effects. Extended oral, written and multimodal texts and presentations are created, adapted and refined for a variety of contexts, purposes and audiences. Effective research strategies and referencing protocols are used to present ideas, information, arguments and evidence, conclusions and recommendations.

The thematic focus for Unit 4 is language and empowerment. Using knowledge and skills from their existing languages and cultures, students learn to use English to explore the relationship between the uses of language and the concept of the power of language.

Through building on knowledge of the ways in which language can be used to influence, persuade and position people, students examine how it can also be used to privilege or marginalise individuals, social groups, ideologies, beliefs and values. Development of these understandings enables students to choose to use language appropriate for audience and purpose, moving between language varieties and situations confidently.

Students explore how cultural conceptualisations are embedded in language and how power relationships are created through persuasive and rhetorical devices. This knowledge, and the ability to select and control language to suit context, provides 'empowerment'.



HEALTH & PHYSICAL EDUCATION

HEALTH & PHYSICAL EDUCATION

General Courses					
Year 11 (Unit 1 & 2)	Code	Cost	Year 12 (Unit 3 & 4)	Code	Cost
Physical Education Studies	GEPES	\$120	Physical Education Studies	GPES	\$120
Outdoor Education	GEOED	\$270	Outdoor Education	GTOED	\$270
Health Studies	GEHEA	\$45	Health Studies	GTHEA	\$45
ATAR Courses					
Year 11 (Unit 1 & 2)	Code	Cost	Year 12 (Unit 3 & 4)	Code	Cost
Physical Education Studies	AEPEs	\$140	Physical Education Studies	ATPEs	\$140
Health Studies	AEHEA	\$60	Health Studies	ATHEA	\$60
Certificate Qualifications (2 Year Delivery)					
Year 11 Certificate II in Sport Coaching S1S20321 (course begins)		\$200	Year 12 Certificate II in Sport Coaching S1S20321 (course continues)		\$120

* **Costs are estimates and are subject to change.**

* **The camps offered will incur an extra cost.**

PHYSICAL EDUCATION STUDIES GENERAL COURSE

Prerequisites

None

Theory - 50%

Practical - 50%

Year 11 GEPES

UNIT 1 & 2

The Physical Education Studies General course focuses on the complex interrelationships between motor learning and psychological, biomechanical and physiological factors that influence individual and team performance. Students engage as performers, leaders, coaches, analysts and planners of physical activity. Physical activity serves both as a source of content and data and as a medium for learning.

The course prepares students for a variety of post-school pathways, including immediate employment or tertiary studies. It provides students with an increasingly diverse range of employment opportunities in the sport, leisure and recreation industries, education, sport development, youth work and health and medical fields linked to physical activity and sport. The course also equips students to take on volunteer and leadership roles in community activities.

YEAR 11 and 12 Pathways

Course Information Handbook 2027

The Physical Activity contexts will be chosen from:

- Softball
- Badminton
- Netball/Basketball

Course Content:

- Body systems and exercise
- Body movement analysis in sport
- Skill acquisition and tactics in sport
- Coaching
- Umpiring
- Fitness testing and Fitness programs
- Goal setting for personal improvement
- Attitudes and values to physical activity

Year 12 GTPES

Unit 3 & 4

This course will appeal to students who are intending to pursue a tertiary studies or employment pathway.

Recommendation: A pass in Year 11 PE Studies.

The focus of this unit is to explore functional anatomy, energy systems, training principles, biomechanics concepts that provide a basis for assessing and enhancing their own and others' performance. It also covers nutrition, goal setting, tactics and strategies which enhance their own and others' performance in physical activity. Sports that will be played are Tennis, Volleyball and Touch. The course contains both theoretical and practical assessment components.

OUTDOOR EDUCATION GENERAL COURSE

Theory - 50%

Practical - 50%

Course Requirements

7.15am start one day per week (go home early on another day).

Through interaction with the natural world, Outdoor Education aims to develop an understanding of our relationships with the environment, others and ourselves. The ultimate goal of this course is to contribute towards a sustainable world.

The Outdoor Education Course focuses on outdoor activities and features an adventurous, out-of-doors component. Environments that provide relevant practical experiences for students are unlimited. They include short duration, part of day or whole day excursions to local environments and extended multiple-day expeditions to more remote locations beyond Perth.

Year 11 GEOED

The camps offered will incur an extra cost.

Prerequisites

Prior to participation in sailing or sailboarding, the-teacher-in-charge must ensure that students have the required swimming and water safety skills to participate safely. Student capacity will be assessed as per the Outdoor Education and Recreation policy guidelines. If it is not appropriate for the assessed student to continue to participate in the activity another course will have to be selected.

UNIT 1 & 2

The practical activities will be chosen from:

1. Sailing (UNIT 1)
2. Orienteering (UNIT 1)
3. Abseiling (UNIT 2)
4. Bushwalking (UNIT 2)

COURSE CONTENT

Outdoor Experiences:

- Planning
- Skills and practices
- Safety

Personal & Group Development:

- Personal development
- Group development
- Leadership

Environmental Awareness:

- The environment
- Human impact
- Environmental management

Year 12 GTOED

The camps offered will incur an extra cost.

Prerequisites

Prior to participation in water based activities, the-teacher-in-charge must ensure that students have the required swimming and water safety skills to participate safely. Student capacity will be assessed as per the Outdoor Education and Recreation policy guidelines. If it is not appropriate for the assessed student to continue to participate in the activity another course will have to be selected. This course will appeal to students who are intending to pursue a TAFE or employment pathway.

Recommendation: A pass in Year 11 Outdoor Education.

UNIT 3 & 4

The focus of this unit is experience the challenges of the outdoors. The students will engage in a range of outdoor adventure activities that will help them develop and improve their technical skills and apply them in a safe manner. They will develop personal skills, decision-making skills as well as reflecting on their outdoor experience and their interaction with nature. The main outdoor activities are; snorkeling, fishing, surfing, kayaking, and camping skills. The course contains both theoretical and practical assessment components.

HEALTH STUDIES GENERAL COURSE

Prerequisites

None

The English as an Additional Language or Dialect (EAL/D) ATAR course focuses on language learning.

Year 11 GEHEA

UNIT 1 & 2

In this General course students explore health as a dynamic quality of life. They will consider the way in which beliefs and attitudes influence health decisions and learn how to plan and take action that will promote their own and the health of others. They examine the impact of social and environmental factors on health and use inquiry skills to investigate and respond to relevant issues. The course also provides students with opportunities to develop skills that will enable them to pursue careers in health promotion, research or community health care.

Year 12 GTHEA

UNIT 3 & 4

In this General course students explore health as a dynamic quality of life. They will consider the way in which beliefs and attitudes influence health decisions and learn how to plan and take action that will promote their own and the health of others. They examine the impact of social and environmental factors on health and use inquiry skills to investigate and respond to relevant issues.

The course also provides students with opportunities to develop skills that will enable them to pursue careers in health promotion, research or community health care.

PHYSICAL EDUCATION STUDIES ATAR COURSE

The main sports that will be covered are Touch and Badminton.

Theory - 50%

Practical - 50%

Year 11 AEPES

Prerequisites

Recommended for ATAR English in Year 11.

At least a C grade in Physical Education in Year 10.

UNIT 1 & 2

This course will appeal to students who are intending to pursue university pathways.

The focus of this unit is to explore anatomical and biomechanical concepts, the body's responses to physical activity, and stress management processes to improve own and others' performance in physical activity. It also covers the relationship between skill, strategy and the body in order to improve the effectiveness and efficiency of performance. The course contains both theoretical and practical assessment components.

Year 12 ATPES

Prerequisites

55% or above in AEPES Physical Education Studies.

Unit 3 & 4

This course will appeal to students who are intending to pursue university pathways.

The focus of this unit is to provide opportunities for students to build upon their acquired physical skills and biomechanical, physiological and psychological understandings to improve their own and others' performance in physical activity. It also extends students' understanding of complex biomechanical, psychological and physiological concepts to evaluate their own and others' performance. The course contains both theoretical and practical assessment components.

YEAR 11 and 12 Pathways

Course Information Handbook 2027

HEALTH STUDIES ATAR COURSE

Year 11 AEHEA

Prerequisites

Recommended for ATAR English.

UNIT 1 & 2

In this ATAR course students explore health as a dynamic quality of life. They examine the impact of social, environmental, economic and biomedical determinants on health and their collective contribution to health disparities, as well as exploring approaches to address barriers which prevent groups from experiencing better health. Students apply inquiry skills to examine and analyse health issues, develop arguments and draw evidence-based conclusions. The course also provides students with opportunities to develop skills that will enable them to pursue careers in health promotion, research or community health care.

Year 12 ATHEA

Prerequisites

Pass AEHEA.

Recommended for ATAR English.

UNIT 3 & 4

In this ATAR course students explore health as a dynamic quality of life. They examine the impact of social, environmental, economic and biomedical determinants on health and their collective contribution to health disparities, as well as exploring approaches to address barriers which prevent groups from experiencing better health. Students apply inquiry skills to examine and analyse health issues, develop arguments and draw evidence-based conclusions. The course also provides students with opportunities to develop skills that will enable them to pursue careers in health promotion, research or community health care.



HUMANITIES & SOCIAL SCIENCES

HUMANITIES & SOCIAL SCIENCES

Students selecting HASS ATAR courses should be achieving **at least a high level C grade** (consistent) in Year 10 HASS and English. Recommendations for courses can be discussed with your teacher. The cognitive complexity of the course content in all courses increases from Year 11 to Year 12. The external exam at the end of year 12 (ATAR exam) covers the work completed in both semesters of Year 12.

General Courses					
Year 11 (Unit 1 & 2)	Code	Cost	Year 12 (Unit 3 & 4)	Code	Cost
Aboriginal and Intercultural Studies	GEAIS	\$49	Aboriginal and Intercultural Studies	GTAIS	\$49
Business Management and Enterprise	GEBME	\$47	Business Management and Enterprise	GTBME	\$47
Geography	GEGEO	\$49 + Fieldwork Chargers	Geography	GTGEO	\$49 + Fieldwork Chargers
History – Ancient	GEHIA	\$49	History – Ancient	GTHIA	\$49
History – Modern	GEHIM	\$49	History – Modern	GTHIM	\$49
Psychology	GEPSY	\$49	Psychology	GTPSY	\$49
ATAR Courses					
Year 11 (Unit 1 & 2)	Code	Cost	Year 12 (Unit 3 & 4)	Code	Cost
Aboriginal and Intercultural Studies	AEAIS	\$49	Aboriginal and Intercultural Studies	ATAIS	\$49
Accounting and Finance	AEACF	\$47	Accounting and Finance	ATACF	\$47
Business Management and Enterprise	AEBME	\$47	Business Management and Enterprise	ATBME	\$47
Economics	AEECO	\$47	Economics	ATECO	\$47
Geography	AEGEO	\$46 + Fieldwork Chargers	Geography	ATGEO	\$46 + Fieldwork Chargers
History – Ancient	AEHIA	\$46	History – Ancient	ATHIA	\$49
History – Modern	AEHIM	\$49	History – Modern	ATHIM	\$49
Politics & Law	AEPAL	\$47	Politics & Law	ATPAL	\$47
Psychology	AEPSY	\$49	Psychology	ATPSY	\$49
Certificate Qualifications (2 Year Delivery)					
Year 11 Certificate II in Workplace Skills (BSB20120)		\$139	Year 12 Certificate III in Business (BSB30120) (on recommendation)		\$139

* **Costs are estimates and are subject to change.**

* **Fieldwork Charges are to be advised.**

YEAR 11 and 12 Pathways

Course Information Handbook 2027

ABORIGINAL AND INTERCULTURAL STUDIES GENERAL COURSE

Prerequisites

None

Aboriginal histories and cultures are fundamental to the development of Australian identity and the formation of contemporary Australian society and as such are a focus of this course. In Year 11, students explore the concept of leadership through the arts, sports and the struggle for civil rights in Australia and in other countries. Students also investigate how culture is expressed through the arts and how this cultural expression has changed over time. In Year 12, students investigate the relationship of First Nations peoples with the environment, and cultural interaction and resilience.

Year 11 GEAIS

UNIT 1 – DIVERSITY OF AUSTRALIAN FIRST NATIONS PEOPLES' CULTURAL IDENTITIES

The focus for this unit is to develop knowledge and understanding of Australia's First Nations Peoples as being the oldest living continuous cultures in the world. Students explore factors that contribute to a group, or individual, identity. Students further develop their understanding of the diversity of First Nations Peoples' experiences and perspectives, locally, nationally, and globally and develop an awareness of the ways First Nations Peoples' identities are expressed through unique ways of being, knowing and doing.

UNIT 2 – DIVERSITY OF AUSTRALIAN FIRST NATIONS PEOPLES' CULTURAL EXPRESSIONS AND PROTOCOLS

The focus of this unit is for students to learn about the distinctiveness and diversity of Australian First Nations Peoples' cultural expressions. They learn how First Nations Peoples, both within Australia and internationally, continue to use materials and technologies in innovative ways to create cultural expressions that celebrate, challenge and communicate ideas and perspectives. Students explore the use of First Nations Peoples' cultural expressions to continue, maintain, share and revitalise their cultural knowledge and values and, in doing so, develop respect and understanding of the cultural protocols, including intellectual and cultural property rights, which exist to protect and revitalise First Nation Peoples' cultures.

Year 12 GTAIS

UNIT 3 – CONNECTION TO AND CARING FOR COUNTRY

This unit enables students to explore the relationship Australian First Nations Peoples, and other First Nations Peoples around the world, have with Country and the environment. They learn the important roles Country and the environment play in the lives, culture and identity of First Nations Peoples, from education and knowledge sharing, ceremony and celebration, management of contemporary environmental threats and economic opportunities.

UNIT 4 – RESILIENCE AND RECONCILIATION

This unit enables students to explore the idea of cultural resilience and Reconciliation. They learn that cultural change results from a range of external and internal factors and may be welcomed or resisted. Students explore how individuals and groups show self-determination, resilience and actively participate in growing Reconciliation in Australia and globally.

BUSINESS MANAGEMENT AND ENTERPRISE GENERAL COURSE

Prerequisites

None

The Business Management and Enterprise General course focuses on establishing and operating a small business in Australia and aims to provide students with an understanding of the knowledge and skills of the processes and procedures required for generating business ideas and turning them into a viable business venture. Factors that impact on business innovation and success, business planning, and legal aspects of running a small business are examined. Students engage in the running of a small business, or participate in business simulations, to develop practical business skills and to develop financial and business literacy. Through the consideration of real businesses and scenarios, students develop knowledge, understanding and skills that enable them to analyse business opportunities, develop proposals and make sound, ethical business decisions. The course equips students to participate proactively in the world of business, behave responsibly and demonstrate integrity in business activities.

Year 11 GEBME

UNIT 1 – ESTABLISHING A SMALL BUSINESS IN AUSTRALIA

The focus of this unit is on establishing a small business in Australia. Opportunities are provided to explore business start-ups and to recognise the factors that contribute to business success. Entrepreneurship and innovative thinking are introduced, generating ideas and proposals that may be suitable for business ventures. These proposals are then developed into a business plan.

UNIT 2 – OPERATING A SMALL BUSINESS IN AUSTRALIA

The focus of this unit is on operating a small business in Australia. The unit is suited to the running of a small business in the school or local environment, or to the use of business simulations. The concepts of innovation, marketing and competitive advantage and the key factors that influence consumer decision making are introduced. Legal aspects of running a small business, including rights and responsibilities of employer and employee, are investigated.

Year 12 GTBME

UNIT 3 – SUCCESS IN BUSINESS

The focus of this unit is on success in business at a national level. It explores what it takes to be successful beyond the initial start-up stage. Students investigate the features of successful marketing campaigns and report on how businesses succeed and prosper through methods, such as expansion in products, market share or diversification. The unit explores how the marketing plan contributes to the overall business plan.

The course content encompasses theoretical and practical aspects of business management and enterprise, and is divided into three content areas:

- Environments
- Management
- People

UNIT 4 – BUSINESS GROWTH AND CHALLENGES

The focus of this unit is on business growth and the challenges faced by businesses expanding at a national level. The unit explores issues in the business environment, including the importance of intellectual property in protecting business ideas. The unit addresses the significance of employee motivation and the development of a business plan in the overall success of expansion. The course content encompasses theoretical and practical aspects of business management and enterprise, and is divided into three content areas:

- Environments
- Management
- People

YEAR 11 and 12 Pathways

Course Information Handbook 2027

GEOGRAPHY GENERAL COURSE

Prerequisites

None

Jobs in Geography form an important part of Western Australia's economy – helping build billion dollar industries in areas like Mining, Tourism and Construction. Students who take General Geography will gain a strong knowledge and understanding of the natural and social systems of our environment, and be well prepared to take up a range of jobs in exciting and lucrative industries both in Australia and internationally. Students who take General Geography will have the opportunity to get out of the classroom and be involved in a range of practical, hands on projects, to learn about how Geography can help people develop sustainable solutions to problems in their local area.

Year 11 GEGEO

UNIT 1 – GEOGRAPHY OF ENVIRONMENTS AT RISK

In this unit, students develop their knowledge and skills about the world in which they live. We will take a trip down to the beach and learn about the impact of Perth's growing population on our precious coastal environments. This unit will prepare students for careers in environmental protection/rehabilitation, urban and regional development, and tourism. In this unit students investigate our beautiful coastline, and research places such as Hillarys and Sorrento, the Californian Coast, and learn about our precious coral reefs, such as Ningaloo and the Great Barrier.

UNIT 2 – GEOGRAPHY OF PEOPLE AND PLACES

People choose where to live, work and play, based on a number of important considerations. This unit looks closely at Perth and examines the different cultural, social and economic hubs within the region. What makes Perth such a great place to live, This unit investigates a number of development issues and how these are impacting upon people and places. Students will get out into our local area and do some practical Geocaching in the local area. In this unit, students will gain practical skills to work in industries from real estate to grounds keeping, construction to mining.

Year 12 GTGEO

UNIT 3 – NATURAL AND ECOLOGICAL HAZARDS

In this exciting unit students explore natural hazards, including atmospheric, hydrological and geomorphic hazards; including, storms, cyclones, tornadoes, frosts, droughts, bushfires, flooding, earthquakes, volcanoes and landslides. They will also explore ecological hazards; for example, environmental diseases/pandemics (toxin-based respiratory ailments, infectious diseases, animal-transmitted diseases and water-borne diseases) and plant and animal invasions. Could you survive? Students will look at one of these issues in depth and have the opportunity to gain skills in the latest Geographic information technology applications.

UNIT 4 – GLOBAL NETWORKS AND INTERCONNECTIONS

Our world is linked in ways that it has never been connected before. In this unit students learn about global connections and the power of the Internet. The unit looks at the ways people and places embrace, adapt to, or resist the forces of change. Students will research music, sport and giant multinational conglomerates, and how they use avenues such as online retailing and Facebook, to connect people around the globe. This unit will include an excursion to visit Perth's Retail and Entertainment zones.

HISTORY – ANCIENT GENERAL COURSE

Prerequisites

None, although an interest in applying mythology to ‘real life characters’ is important.

Year 11 GEHIA

UNIT 1 – ANCIENT CIVILISATIONS AND CULTURES

This unit enables students to investigate life in early civilisations, including the social, cultural, political, economic, religious, and military structures, and the significant values, beliefs, and traditions that existed. They discover how the world and its people have changed, as well as the significant legacies that exist into the present. This will include one of the following electives:

- Early Dynastic and Old Kingdom Egypt, (Dynasty 0–6, 3100–2181 BC) ;
- Late Bronze Age of Greece and Troy (~1500–1050 BC); or
- Pompeii and Herculaneum and the Roman world (80 BC–AD 79).

UNIT 2 – POWER IN THE ANCIENT WORLD

In this unit, students learn that in ancient societies key individuals have created change – through revolution or peace – with groups and institutions, and using their power to shape their society. They investigate key individuals’ motives, methods and power; the responses of others to their power, and their impact and influence on society.

This will include two of the following alternative electives:

- Akhenaten (Egypt, c. 1352–c. 1336 BC);
- Alexander the Great (Macedonia 356–323 BC);
- Julius Caesar (Rome BC 100–44) and Agrippina the Younger (Rome AD 15–59); or
- Cleopatra (Egypt, c. 51–30 BC).

Year 12 GTHIA

UNIT 3 – SOCIETIES AND CHANGE

In this unit, students learn about the evolving nature of societies and the various forces for continuity and change that exist. They also learn that values, beliefs, and traditions are linked to the identity of a society. Students will examine aspects such as mythology and slavery in the targeted ancient society. This will include one of the following electives:

- Ancient Egypt (Dynasties 17–19 ~ 1560–1504 BC and 1327–c. 1213 BC); or
- Rome (the Late Republic to the Lex Manilia 133–66 BC).

UNIT 4 – CONFRONTATION AND RESOLUTION

In this unit, students learn that there are internal and external forces that result in confrontation and revolution within societies. Students will examine the fall of great Roman and Athenian Republics. This will include one of the following electives:

- The conflict between the Greeks and Persian Empire to the Battles of Plataea and Mycale, (512–478 BC); or
- Rome, from Pompey’s Eastern Command to the First Settlement of Augustus (66–27 BC); or
- Philip II and Alexander the Great of Macedon and the wars of the successors.

HISTORY – MODERN GENERAL COURSE

Prerequisites

None

The Modern History General course provides students with an understanding of the driving forces behind present local and global issues. Investigating the past helps students to understand why and how groups and/or societies changed or resisted change. This course promotes skills of research, hypothesis testing and analysis of information when engaging with investigations. Through inquiries, provisional and tentative historical judgments are made. Students are encouraged to question and evaluate historical sources; to identify the various representations and versions of history.

Year 11 GEHIM

UNIT 1 – PEOPLE, PLACE AND TIME

Students will study one or two of the following electives:

- Nicholas II and the decline of Tsarism in Russia
- Charles Perkins, Eddie Mabo, Faith Bandler and others:
Aboriginal advancement since the 1950s to the Apology
- Nelson Mandela and the fight to end apartheid in South Africa

The impact of change – politically, economically, internationally, socially and through leadership will be considered and discussed.

UNIT 2 – POWER AND AUTHORITY

Students will study one or two of the following electives;

Imperial power and authority:

- Imperial power and authority: the French in Indo-China
- Imperial power and authority: the Dutch in the East Indies
- International authority: the League of Nations and the United Nations
- Authoritarian state: Tokugawa Japan
- Authoritarian state: Communist Russia/USSR 1917–1953

The impact of change – politically, economically, internationally, socially and through leadership will be considered and discussed.

Year 12 GTHIM

UNIT 3 – SOCIETIES AND CHANGE

Students learn about the evolving nature of societies and the various forces for continuity and change that exist. Students study one of the following electives which is to be taught with the requisite historical skills described as part of this unit.

- Australia 1914–1949
- The Meiji Restoration 1853–1911
- The USA between the wars 1918–1941

The impact of change – politically, economically, internationally, socially and through leadership will be considered and discussed.

UNIT 4 – HISTORICAL TRENDS AND MOVEMENTS

Students will study one of the following electives:

Post-war de-colonisation movements in Vietnam or Indonesia or East Timor

- Nazism in Germany 1918–1945
- The civil rights movement in the USA 1941–1971
- Terrorism and peace movements 1946–2001

The impact of change – politically, economically, internationally, socially and through leadership will be considered and discussed.

YEAR 11 and 12 Pathways

Course Information Handbook 2027

PSYCHOLOGY GENERAL COURSE

Prerequisites

None, although limited mathematical ability is required for the General Psychology courses. Students are expected to be able to use simple mathematical skills they have developed in Year 7–10, and use calculators.

This course is a scientific study of how people think, feel and act. It is about the complexities of human behaviour looking at oneself and others around us in the community.

Year 11 GEPSY

UNIT 1 – SELF (PERSONALITY & COGNITION) AND OTHERS (RELATIONAL INFLUENCES & COMMUNICATION)

This unit looks at how and why people behave as they do. Students learn about the human brain and explore the impact of external factors on behaviour, such as hormones and drugs. They examine different types of relationships and the role of communication in initiating, maintaining and regulating relationships. Students explore what is meant by the term personality and examine historical perspectives used to explain personality, they explore behaviour and some causes of prejudice. Students are also introduced to ethics in psychology and carry out investigations.

UNIT 2 – SELF (BIOLOGICAL INFLUENCES & DEVELOPMENTAL PSYCHOLOGY) AND OTHERS (SOCIAL PSYCHOLOGY, CULTURE AND VALUES)

This unit introduces the brain. Students explore the impact of factors influencing behaviour, emotion, thought etc. Consideration is given to group behaviour and the impact of the size of the group. There is a focus on developmental psychology, analysing twin and adoption studies to gain insight into the nature/nurture debate and look at the role of play and parenting in assisting development. The influence of culture in shaping attitudes towards issues such as mental health is looked at in detail.

Year 12 GTPSY

UNIT 3 – SELF (PERSONALITY & COGNITION) AND OTHERS (RELATIONAL INFLUENCES & COMMUNICATION)

This unit focuses on the functions of brain and examines how messages are transmitted from the brain to the body. It explores how behaviour is influenced by learning and other factors, and the impact of others on individual behaviour. Theorists such as Pavlov are studied. Students examine socialisation processes (friendship development) observed within families and peer groups, and how social background and gender can shape communication styles. There is also a focus on developmental and contemporary personality theories, and behaviours observed when individuals are examined in the social context.

UNIT 4 – SELF (BIOLOGICAL INFLUENCES & DEVELOPMENTAL PSYCHOLOGY) AND OTHERS (SOCIAL PSYCHOLOGY, CULTURE AND VALUES)

Students analyse the causes of conformity and obedience and gain an understanding of the factors that shape a sense of community. Students expand on their knowledge of ethics in psychological research as they engage in detailed investigations. Students look at the links between the brain and behavior, considering developmental psychology (Piaget) and moral development (Kohlberg).

ABORIGINAL AND INTERCULTURAL STUDIES ATAR COURSE

Prerequisites

A very strong C grade in Year 10 HASS and English is required to ensure success in this ATAR course.

Aboriginal histories and cultures are fundamental to the development of Australian identity and the formation of contemporary Australian society and as such are a focus for this course. In Year 11, students explore the relationship of First Nations peoples with the environment and also cultural interaction and resilience. In Year 12, students investigate the concept of media representation within and between cultures in Australia and other countries, and also the concepts of heritage and cultural identity in an Australian context. In both years students critically explore a wide range of political, social, historical, legal and environmental issues from an intercultural perspective.

Year 11 AEAIS

UNIT 1

The focus for this unit is the relationship First Nations Peoples in Australia and other countries have with the environment. Within this broad area and by privileging First Nations Peoples' voices and perspectives, students investigate First Nations Peoples' continuous connection and care of Country. They investigate First Nations Peoples' technological innovations and responses to changes in technology and the environment. Students explore the contributions of First Nations Peoples and how cultures incorporate change while maintaining continuity of tradition with respect to the environment.

UNIT 2

The focus for this unit is on cultural interaction and resilience. Students explore how cultural change results from a range of factors and commonly involves interaction between different cultures. They investigate the ways individuals and groups show cultural resilience as they seek to maintain their cultural identity. Students also investigate interactions between cultures with different world views, how they respond to one another, and how they each maintain continuity.

Year 12 ATAIS

UNIT 3

The focus for this unit is the resiliency of Australian First Nations Peoples' heritage and cultural identities. The concept of heritage is an essential component in the formation of Australian First Nations Peoples' cultural and personal identities. Students investigate initiatives and programs, which use Australian First Nations Peoples' cultural practices, knowledge, beliefs and values and how they contribute to the empowerment of Australian First Nations Peoples. Within this investigation students examine the ongoing impacts of colonisation and social disadvantage.

UNIT 4

The focus for this unit is media representation of Australian First Nations Peoples. Students investigate the influence that forms of media have on contemporary society. They explore the changing representation of First Nations Peoples in the media and how this media representation can be used to shape or challenge values and beliefs, as well as to reflect them. Students examine the policies, laws, history interpretations and actions aimed at recognising, acknowledging and empowering First Nations Peoples in Australia. Within this broad area students focus on privileging First Nations Peoples' voices and perspectives.

ACCOUNTING AND FINANCE ATAR COURSE

Prerequisites

Students will be on an ATAR pathway, with an average of 60% in Maths and a C grade in English.

The Accounting and Finance course aims to make students financially literate by creating an understanding of the systems and processes through which financial practices and decision making are carried out, as well as the ethical, social and environmental issues involved. It helps students develop the ability to analyse and make informed decisions about finances. In an age when many business practices and ethical standards are being questioned, awareness of the ways financial practices impact on their lives helps students take responsibility for their own financial commitments. It gives them the problem-solving skills to operate at many levels of financial decision-making.

Year 11 AEACF

UNIT 1 – DOUBLE ENTRY ACCOUNTING FOR SMALL BUSINESSES

On completion of this unit students will be able to apply their understanding of financial principles, systems and institutions to manage financial information and make decisions in a variety of small businesses; develop an understanding of the rationale for the use of particular accounting conventions and principles; record and process financial information using the double-entry system; apply the principles of Goods and Services Tax (GST); and outline the various forms of business organisations which can be adopted by small business.

UNIT 2 – ACCRUAL ACCOUNTING

Through this unit students will learn to apply financial systems and principles to the operations of businesses; distinguish between cash and accrual methods of accounting; prepare and analyse financial reports for a variety of types of business organisations; become familiar with the main aspects of electronic processing of financial data; and have an understanding of the role and functions of the professional accounting and financial associations.

Year 12 ATACF

UNIT 3 – INTERNAL MANAGEMENT FOR BUSINESSES

On completion of this unit students will be able to: prepare and interpret budgets and performance reports in relation to forecasting a business's future; distinguish between internal and external reporting requirements; apply decision making processes using cost accounting techniques; critically analyse financial information; and identify the importance of short and long term planning for business.

UNIT 4 – AUSTRALIAN REPORTING ENTITIES AND HOW THEY ARE REGULATED BY THE CORPORATIONS ACT 2001

This unit builds on the content covered in Unit 3, with students establishing a clear understanding of the Australian government bodies that regulate small businesses. Students will be able to identify and evaluate the financing options of larger entities, particularly in relation to conformity with basic principles, including profitability and stability; use the Framework for the Preparation and Presentation of General Purpose Financial Reports (The Framework) and the Accounting Standards, students will be able to prepare financial statements for a reporting entity. Likewise they will be able to address the issues relating to corporate social disclosure and ethical behaviour within corporations.

BUSINESS MANAGEMENT AND ENTERPRISE ATAR COURSE

Prerequisites

Students will be on an ATAR pathway and with an average of at least 60% across all subjects in Year 10, and a C grade in English.

Businesses have complex and dynamic structures that require a combination of skills, aptitude, creativity, and entrepreneurial ability to operate effectively. In an increasingly global world, businesses must constantly respond to changing environments, adapt to culturally diverse employees, customers and management styles, in order to generate long-term profits that sustain a continued existence.

Year 11 AEBME

UNIT 1 – SUCCESS IN BUSINESS AT A NATIONAL LEVEL

Students will initially study the concepts, structures and factors underpinning business performance on a national level. Specific content area includes marketing, leadership, management, organisational practices and structures. Once students have gained an understanding of how businesses function, they will explore the relationships between business and society. Successful marketing campaigns will be analysed to identify what makes them successful. They will explore how economic environments, government policies, legal requirements and society's beliefs and values impact business.

UNIT 2 – BUSINESS GROWTH AND CHALLENGES TO BE FACED

Finally students will learn how to apply business skills, tools and processes to effectively manage and grow businesses on a national level. This will require the demonstration of effective interpersonal skills, and the investigation and evaluation of innovative and enterprising opportunities. Intellectual property, employee motivation and successful business plans will be studied. Learning experiences will typically include case studies, current affairs, management reports, marketing plans and financial data.

Year 12 ATBME

UNIT 3 – STRATEGIC INTERNATIONAL BUSINESS GROWTH

Students will build on the concepts, structures and factors underpinning business performance studied in the Year 11 course, but in a global context. Specific content area includes globalisation, free trade agreements, international marketing and trade, and the theories of management, innovation and change management. Students will explore the political, legal, economic and social issues that surround global businesses. They will gain an understanding of corporate ethics, social responsibility and sustainability, and the impact that globalisation has had on businesses and world markets.

UNIT 4 – GLOBAL BUSINESS OPERATIONS

Once students have gained an understanding of the issues that confront global businesses, they will study the purpose and intent of the strategic planning process, the features of operations management including production management systems, quality control and inventory management systems and the financial management issues that confront international businesses. Learning experiences will typically include case studies, current affairs, management reports, feasibility studies, marketing plans and financial data.

ECONOMICS ATAR COURSE

Prerequisites

A very strong C grade in Year 10 HASS and English needs to be achieved to ensure success in ATAR Economics. A minimum recommendation for Maths Applications is also desirable.

Economics is about the world around us; it's current; it's always changing; it's always interesting. It's about the modern world; it's about how we behave, how businesses behave and how the government behaves. Economics teaches us how to make well-informed decisions or choices – in life and in business. Indeed, economics is a great foundation for many careers. The skills developed in this course relate to a variety of qualifications in vocational, technical and university courses. Economic literacy developed through this course enables students to actively participate in economic and financial decision-making, which promotes individual and societal wealth and wellbeing. Economics complements the courses of Accounting & Finance and BME.

Year 11 AEECO

UNIT 1 – MICROECONOMICS

What happens in a market? This unit is an introduction to microeconomics and explores the role of the market in determining the wellbeing of individuals and society. Students explore the workings of real world markets with an emphasis on the Australian economy. We explore the theory that markets are an efficient way to allocate scarce resources, using real world markets with an emphasis on the Australian economy.

Market occasionally fails – e.g. when firms have immense market power or when the negative impact on the environment is not accounted for. Consequently, the misallocation of resources creates inefficiency and inequitable or unsustainable results. Market failure can occur. Students examine examples of market failure along with a range of government policy options that can be applied to achieve more desirable outcomes. Students are also introduced to the language of economics and the use of theories and models to explain and interpret current economic issues and events.

UNIT 2 – MACROECONOMICS

What goes up must come down and then rise again. This is true for the economy as well. What will Australia be like 10 years, 20 years on? This unit explores economic growth, inflation and unemployment with an emphasis on the Australian economy. Students learn it is important to measure and monitor changes in these macroeconomic indicators as changes in the level of economic activity affect the wellbeing of individuals and society.

Exploration of the government's role in a modified market economy and Australia's recent (the last ten years) and contemporary (the last three years) macroeconomic performance. The cyclical fluctuations in the level of economic activity result in changes in the levels of output, income, spending and employment in the economy – which, in turn, have implications for economic growth, inflation and unemployment. Students examine the role of government, through its spending and taxing powers, which can affect the allocation and price of resources, and the level of economic activity by targeting economic objectives such as sustainable economic growth, price stability and full employment.

Year 12 ATECO

UNIT 3 – AUSTRALIA AND THE GLOBAL ECONOMY

“Trade wars, Supply-chain issues, sky-rocketing inflation.”

World events shape our economies. This unit explores the interdependence of Australia and the rest of the world. Australia is a relatively open economy and, as such, is influenced by changes in the world economy. Trade liberalisation and protection and the impact of foreign investment, exchange rate and terms of trade in shaping the Australian economy now and in the future are considered. Students examine Australia’s trade, the recording of international transactions and the impact of these transactions on the Australian economy. Students examine the effects of changes in Australia’s economic transactions with the rest of the world using recent and contemporary economic data – with economic models.

UNIT 4 – MACROECONOMIC THEORY AND ECONOMIC POLICY

How well is the Australian economy tracking? Why are interest rates rising? Should we be concerned about Australia’s trillion-dollar debt? This unit explores the economic objectives of the Australian Government and the actions and policies, such as fiscal policy, monetary policy and policies aimed at improving productivity, operate in the pursuit of the Australian Government’s economic objectives. Students examine the effects of the operation of policies in Australia using economic models along with recent and contemporary economic data. Students apply the language, theories and tools of economics to develop a critical perspective on the role of these policies in the current Australian Government policy mix.

GEOGRAPHY ATAR COURSE**Prerequisites**

ATAR Geography requires a very strong C grade in Year 10 HASS and English. A commitment to field work is important.

The cost of extra book hire to supplement the text purchased by students is included in the course charges. Fieldwork is required in this course, to enhance understanding of concepts studied in class. These costs will be kept to a modest amount.

Year 11 AEGEO

UNIT 1 – NATURAL AND ECOLOGICAL HAZARDS

Tornadoes in North America, floods in the eastern states of Australia and bushfires in Perth remind us that our planet is a risky place to live. Every year natural and ecological hazards result in the loss of human life and cause damage to billions of dollars’ worth of property. It’s not all gloom and doom however; we can take action to ensure that risks posed by these hazards are minimized by prevention, mitigation and preparedness, Two depth studies will be undertaken:

1. A natural hazard (atmospheric, hydrological or geomorphic);
2. An ecological hazard (environmental diseases/pandemics, or plant and animal invasions)

UNIT 2 – GLOBAL NETWORKS AND INTERCONNECTIONS

Every time you go online you have the potential to access people, products and information from anywhere the world. Technological changes such as the development of the Internet as well as the development of megaships and mega planes are studied. The unit also considers the position of the United States and Europe as China and India emerge as global economic and cultural powers.

Two depth studies will be the focus:

1. the reasons for, and consequence of, the changing pattern of production and consumption of a commodity, good or service;
2. the diffusion, adoption and adaptation of an element of culture.

YEAR 11 and 12 Pathways

Course Information Handbook 2027

Year 12 ATGEO**UNIT 3 – GLOBAL ENVIRONMENTAL CHANGE**

Google Earth is just one of the digital tools we can use to see how the surface of our planet is changing. Our activity is altering the Earth's natural environments. As we replace natural vegetation with concrete and asphalt we interfere with important natural systems not the least of which is the climate system. Two depth studies will be the focus:

1. the link between changes in land cover and changes in either global climate or biodiversity;
2. how the impacts of land cover change are being addressed and evaluated.

UNIT 4 – PLANNING SUSTAINABLE PLACES

Given a choice would you prefer to live in the city or the country? If you are like most people on the planet today you would choose to live in a city. Most Australians live in large urban areas like Perth. We all have an interest in making sure our urban areas are sustainable. This unit investigates issues, such as why Perth freeways have become car parks during peak hour, and how our sewerage might solve our city's problem of a diminishing water supply. What planning can be undertaken to ensure cities provide our needs? Two in depth studies will be conducted:

1. significant challenges facing the Perth Metropolitan Area;
2. two significant challenges faced by megacities (eg New York, Tokyo or Jakarta).

HISTORY – ANCIENT ATAR COURSE**Prerequisites**

A very strong C grade in Year 10 HASS and English is required to ensure success in this ATAR course.

The study of Ancient History has stimulated our imagination through the last two millennia, more recently inspiring a plethora of block buster films such as *Gladiator*, *Troy*, *Pompeii* and *300*. Western society has striven to imitate the Ancient world of Greece, Rome and Egypt in many aspects of our government, art and architecture. Yet so much that we think we know about the ancient world are fallacies that we project onto the past. Ancient Greece was the birthplace of democracy, yet a quarter of the population were slaves and women had to veil their face in public. Ancient Rome controlled an empire larger than the European Union united through warfare and maintained by the spectacle of slaughter in the Gladiatorial games. During the glory and grandeur of Rome, they built structures that would not be equalled till modern times, they perfected indoor plumbing and heating yet washed their cloths in urine. Few now know that Cleopatra was not Egyptian and Alexander the Great was Macedonian not Greek. By studying ancient history students are given skills to decipher the past and apply the universal lessons of Ancient History to modern politics and history.

Year 11 AEHIA**UNIT 1 – INVESTIGATING THE ANCIENT WORLD**

This unit provides an introduction to the nature of the remaining evidence of the ancient past and issues relevant to the investigation of the ancient world. The unit involves an investigation of the evidence for an ancient site, individual, group or events and how it has been interpreted and represented. Students also investigate historical authentication and reliability. The connection should be made between the significant issues under investigation and the selected electives.

This will include two of the following electives:

- Troy and its destruction;
- The Roman Games;
- Alexander the Great; or
- Cleopatra.

UNIT 2 – ANCIENT SOCIETIES

This unit examines how people lived in the ancient world through an investigation of the remaining evidence. The unit focuses on the study of significant features of ancient societies, such as slavery; the family; and beliefs, rituals and funerary practices. This will include one of the following electives:

- Egypt in the Ramesseid Period (19th and 20th Dynasties); or
- Early Imperial Rome – Pax Romana (27 BC–AD 180).

For the selected elective, students investigate the chronological and geographical context; institutions and structures; the ancient historical narrative; and the significant features of the society such as slavery, art and architecture, beliefs and the family.

Year 12 ATHIA**UNIT 3 – PEOPLE, POWER AND AUTHORITY**

This unit examines the nature and exercise of power and authority in ancient societies in key periods, with reference to the evidence of significant political, military, religious, cultural and economic features. The study of an individual as part of this unit enables study of the influence of the individual on events and developments. This will include:

- Rome 133–63 BC; and either
- Marius; or
- Pompey.

UNIT 4 – RECONSTRUCTING THE ANCIENT WORLD

This unit focuses on a significant historical period to develop an understanding of the relevant institutions, practices, key events and individuals of the period, in the context of a wide range of sources. This unit allows for greater study of the challenges associated with the interpretation and evaluation of evidence. This will include one of the following electives:

- Thebes – East and West, New Kingdom Egypt; or
- Rome 63 BC–AD 14.

HISTORY – MODERN ATAR COURSE**Prerequisites**

A very strong C grade in Year 10 HASS and English is required to ensure success in this ATAR course.

These four units help students make sense of the world, as we know it today. What events over the twentieth century helped shape our nation and those around us? What has helped develop the state of international relations, treaties, fears, politics and policies?

Year 11 AEHIM**UNIT 1 – UNDERSTANDING THE MODERN WORLD**

This unit examines developments of significance in the modern era, including the ideas that inspired them and their far-reaching consequences. Students will study one development or turning point that has helped to define the modern world. Crucial changes such as the challenge to social hierarchy and inheritance; and the assertion of inalienable rights through to government by consent.

Students study one of the following electives:

- The Enlightenment 1750–89
- The American Revolution 1763–1812
- The French Revolution 1774–1804
- The Industrial Revolutions 1750–1890s
- The Age of Imperialism 1848–1914
- The Meiji Restoration – Japan 1853–1911
- Capitalism – the American Experience 1901–41

YEAR 11 and 12 Pathways

Course Information Handbook 2027

UNIT 2 – MOVEMENTS FOR CHANGE IN THE TWENTIETH CENTURY

This unit examines the significant movement for change in the twentieth century that led to change in society, including peoples' attitudes and circumstances. The impact of the studied force will be considered through the economics of the time; external forces/ international relations; developing ideas and leadership; political, social and cultural impacts.

Students study one of the following electives:

- Women's movements
- Recognition and rights of First Nations Peoples
- Decolonisation
- The civil rights movement in the USA
- Workers' movements
- Nazism in Germany
- Movements for peace and security post 1945

Year 12 ATHIM

UNIT 3 – MODERN NATIONS IN THE TWENTIETH CENTURY

This unit examines the 'nation' as the principal form of political organisation in the modern world; the crises that confronted nations in the twentieth century; their responses to these crises, and the different paths they have taken to fulfil their goals. Students study one topic/nation and study crises that challenged the stability of the government, the path of development and the social, economic and political order that has been maintained. Students examine the manner of control a country has developed to deal with internal divisions and external threats.

Students study one of the following electives:

- Australia 1918–49 (the end of World War I to the 1949 election)
- Russia and the Soviet Union 1914–45 (World War I to the end of World War II)
- China 1945–89 (the end of World War II to the Tiananmen Massacre)

UNIT 4 (YEAR 12) – THE MODERN WORLD SINCE 1945

This unit focuses on the distinctive features of the modern world that emerged in the period 1945 – 2001. It aims to build students' understanding of the contemporary world – that is, why we are here at this point in time. These include changes to the nature of the world order: shifting international tensions, alliances and power blocs; the nature of various conflicts and regional and international attempts to create peace and security.

Students study one of the following electives, with a focus on the period 1945–2001:

- The changing European world since 1945
- Australia's engagement with Asia since 1945
- The struggle for peace in the Middle East since 1945

POLITICS AND LAW ATAR COURSE

Prerequisites

A very strong C grade in Year 10 HASS and English is required to ensure success in ATAR PALS. An interest in reading and following political developments is highly desirable.

The Politics and Law ATAR course examines the relationship between the process of making laws and the process of achieving justice primarily in Australia; but with some reference other countries around the world. The course aims to provide students with the knowledge of the key principles, structures, institutions and processes of Australia's political and legal system.

(continued from previous page)

Students will develop values and skills in order to critically evaluate the effectiveness of our political and legal system. They will do this with reference to contemporary examples of issues facing Australian society today, an interest in news and current affairs is essential. The study of Politics and Law is a useful background to careers in law and politics but it extends to areas such as advocacy, public administration, international relations, foreign affairs, community development, teaching, journalism, human resource management, government and commerce.

Year 11 AEPAL

UNIT 1 – DEMOCRACY AND THE RULE OF LAW

This unit examines the key principles of democratic and fair political and legal systems. Content includes; liberal democracy, the Westminster tradition, USA, Canadian and Swiss influences, federation and federalism, common law, adversarial trials and comparisons with non-democratic systems.

UNIT 2 – REPRESENTATION AND JUSTICE

This unit examines the role of elections in achieving representative parliaments. Recent elections will be analysed and comparisons with other electoral systems such as the USA. Students will evaluate the main legal processes and significant civil and criminal trials in Australia and analysis contemporary legal issues such as juvenile justice.

Year 12 ATPAL

UNIT 3 – POLITICAL AND LEGAL POWER

This unit involves a close study of the Commonwealth Constitution (Australia) to understand how power is wielded theoretically and in practice in Australia. The powers of the legislative, executive and judicial branches of government are studied with reference to key people and events that contribute to changes. Political issues such as federalism and recognition of Indigenous Australians in the constitution are examined, as well as landmark High Court Cases.

UNIT 4 – ACCOUNTABILITY AND RIGHTS

In this final unit students examine how effectively the system works to ensure the accountability of the legislature, the executive and the judicial branch. High profile examples where corruption has been uncovered and current methods to detect, prevent and prosecute breaches are studied. Students will also examine how rights are protected in Australia, and make comparisons with the protection of rights in another country, such as the USA.

YEAR 11 and 12 Pathways

PSYCHOLOGY ATAR COURSE

Prerequisites

Students must achieve a very strong C grade in Year 10 HASS and English to ensure success in ATAR Psychology.

The study of Psychology at an ATAR level incorporates scientific research principles. It will prepare students for further studies at university in psychology, health professions, human resources, social sciences, sales, media, law, marketing and management.

Year 11 AEPSY

Unit 1 – BIOLOGICAL AND LIFESPAN PSYCHOLOGY

In this unit students will explore psychological theories, studies, and models that explain human emotion, cognition, and behaviour, and understand how these concepts evolve over time. They will learn about the central nervous system's structure and its impact on thoughts, feelings, and behaviour, and become familiar with methods used to study the brain. The unit also covers lifespan psychology, with a focus on adolescent development. Students will examine how developmental changes influence thoughts, feelings, and behaviours, and extend their understanding by studying attachment and developmental stages as defined by key theorists.

UNIT 2 – ATTITUDES, STEREOTYPES AND SOCIAL INFLUENCES

This unit examines how others influence human behaviour, cognition, and emotion. Students will explore the function and impact of attitudes using the tripartite model, and study theories of cognitive dissonance, social identity, and attribution through relevant psychological studies and real-world applications. The unit also covers social influences, focusing on the role of stereotypes and the relationship between attitudes, prejudice, and discrimination. Students will learn how social influence shapes prosocial and antisocial behaviours and extend their understanding of scientific inquiry and the evolution of psychological knowledge through ongoing research.

Year 12 ATPSY

UNIT 3 – MEMORY AND LEARNING

This unit on Cognitive Psychology focuses on how humans develop and apply understanding of the world. Core components include memory and learning, with various theories explored through psychological research. Students will learn about sensation, perception, and attention in memory, and apply models to understand brain structures and processes related to memory and forgetting. The unit covers learning theories such as classical conditioning, operant conditioning, and social learning, applied to real-world contexts. Science inquiry skills are further developed, emphasizing the evolution of psychological knowledge through ongoing research.

UNIT 4 – PSYCHOLOGY OF MOTIVATION

This unit focuses on understanding human cognition, emotion, and behaviour to improve individual and societal wellbeing. Students will explore the relationship between motivation and wellbeing, applying this knowledge to develop effective strategies for managing stress and improving sleep. By analysing theories and models of motivation and wellbeing, students will understand these concepts and learn psychological techniques to enhance wellbeing. The unit emphasizes the importance of scientific inquiry, applying psychological research to contemporary issues.

CAREER & EMPLOYABILITY AND WORKPLACE LEARNING

Combined General Course and Workplace Learning					
Year 11 (Unit 1 & 2)	Code	Cost	Year 12 (Unit 3 & 4)	Code	Cost
Career & Employability (including Workplace Learning)	GECAE	\$75 + \$150 Workplace Learning Fee	Career & Employability (including Workplace Learning)	GTCAE	\$75 + \$150 Workplace Learning Fee

* **Costs are estimates and are subject to change.**

NOTE: Any Student wishing to enrol in Workplace Learning MUST enrol in the Career and Employability Course.

The Career & Employability General course engages students in learning about developing their career in a constantly changing digital and globalised world. Careers are now considered to be about work, learning and life. Individuals need to be proactive, enterprising career managers who engage in lifelong learning. The course aims to provide students with the knowledge, skills and understanding to enable them to be enterprising and to proactively manage their own careers.

Year 11 GECAE

UNIT 1

This unit enables students to develop the knowledge, understandings and skills associated with exploring work and career options.

UNIT 2

This unit enables students to develop the knowledge, understandings and skills involved with preparing for and participating in entry-level employment.

Year 12 GTCAE

UNIT 3

This unit enables students to develop the knowledge, understandings and skills associated with adopting a proactive approach to securing and maintaining work.

UNIT 4

This unit enables students to develop the knowledge, understandings and skills required for successful workplace participation.

Workplace Learning

- ADWPL Workplace Learning offers you the opportunity to develop industry specific skills through assessment in a workplace environment.
- The program is only available to students selecting Career and Employability as a Course.
- ADWPL is an endorsed program approved by the School Curriculum and Standards Authority.
- During the ADWPL program you will be given the opportunity to learn outside of school by training in the industry of your choice, where possible.
- Students on an ATAR pathway will need to complete ADWPL on the job training during the school holidays.
- Workplace Learning is a partnership – you, the employer and the school all working together.

YEAR 11 and 12 Pathways



LANGUAGES

ATAR Courses					
Year 11 (Unit 1 & 2)	Code	Cost	Year 12 (Unit 3 & 4)	Code	Cost
Chinese: Second Language	AEC SL	\$80	Chinese: Second Language	ATCSL	\$80
Chinese: First Language	AECFL	\$80	Chinese: First Language	ATCFL	\$80
French: Second Language	AEFSL	\$80	French: Second Language	ATFSL	\$80
Italian: Second Language	AEISL	\$80	Italian: Second Language	ATISL	\$80
Japanese: Second Language	AEJSL	\$80	Japanese: Second Language	ATJSL	\$80
Korean: Second Language	AEKOR	\$80	Korean: Second Language	ATKOR	\$80

* Students taking a WACE language course in Year 11 and 12 are required to apply to the School Curriculum and Standards Authority (SCSA) for permission to enrol. This will be done through the Languages Department.

* Costs are estimates and are subject to change.

Mount Lawley Senior High School is a Gifted and Talented Education Languages School. Students accepted through this program are expected to study at least one language in Year 11 and 12.

In Languages, communication is paramount. Students develop the skills and knowledge to communicate in the target language. Communication involves the ability to comprehend, interpret and produce visual, spoken and written texts. Communication is facilitated through the achievement of four outcomes.

Outcome 1 – Listening and responding

Outcome 2 – Spoken Interaction

Outcome 3 – Viewing, Reading and responding

Outcome 4 – Writing

First Language Courses (Chinese) 第一语言课程 (中文)

These courses are aimed at students who have a linguistic and cultural background in the language for which they are applying. 这些课程的对象是拥有所申请语言课程的语言和文化背景的学生。 These students:

- have had formal education in the language for an extended period (five years or more at any time from Pre primary, or the equivalent onwards) in a school where the language is the medium of communication and/ or school instruction, and/or 这些学生在以该语言为交流媒介的学校教学的学校里接受了较长时间 (从学前班或同等学历的五年或以上) 的该语言的正规教育, 和/或
- were born in a country where the language is the medium of communication or have lived in the country for five years or more, and/or 出生在以该语言为交流媒介的国家, 或者在该国家居住过五年或以上, 和/或
- use the language for communication outside the language classroom, and/or 用该语言在语言课外进行交流, 和/或
- are exposed to the language outside the language classroom and have a connection to that culture. 在语言课堂之外接触到该语言, 并与该文化有联系。

Second Language Courses (All languages)

WACE Second Language Courses are aimed at Year 11–12 students for whom the language is a second (or subsequent) language. These students have:

- not been exposed to or interacted in the language outside the language classroom,
- have typically learnt everything they know about the language and its culture through classroom teaching in an Australian school or similar environment, where English is the language of school instruction,
- have typically studied the language for 200–400 hours at the commencement of Year 11, and
- may have experienced some short stays or exchanges (less than two years in total) in a country where the language is a medium of communication.

CHINESE: SECOND LANGUAGE ATAR COURSE

Prerequisites

B Grade or better in Year 10 Chinese.

Year 11 AECSL

UNIT 1

The focus for this unit is 青少年 (Teenagers). Students build on their skills, knowledge and understandings through the study of the unit content. They further develop their communication skills in Chinese and gain a broader insight into the language and culture. Elaboration of outcomes:

- **Having fun:** Students reflect on their favourite activities: sports, going out, and socialising.
- **Student's daily life:** Students explore the daily routines of young Chinese speakers: school, interests, and social activities.
- **Technology and leisure:** Students consider the impact of technology on the lives of young people around the world.

UNIT 2

The focus for this unit is 我们去旅行吧! (Travel – let's go). Students further develop their skills, knowledge and understandings through the study of the unit content. They extend their communication skills in Chinese and gain a broader insight into the language and culture. Elaboration of outcomes:

- **Tales of travel:** Students reflect on their own travel experiences and plans and discuss what is essential when planning a trip and travelling at home and/or abroad
- **Western Australia as a travel destination:** Students explore Western Australia as a destination for Chinese-speaking travellers and discuss how they would prepare a Chinese speaker for a trip to Western Australia.
- **China as a travel destination:** Students consider China as a tourist destination.

Year 12 ATCSL

UNIT 3

The focus for this unit is 目前情况 (Here and now). Students expand their skills, knowledge and understandings through the study of the unit content. They extend and refine their communication skills in Chinese and gain a broader and deeper understanding of the language and culture. Elaboration of outcomes:

- **Relationships:** Students reflect on the different relationships in their lives.
- **Celebrations and traditions:** Students explore major celebrations, traditions and festivals in Chinese communities.
- **Communicating in a modern world:** Students consider how the internet, mobiles, social networking and other technologies are used in building and maintaining relationships

UNIT 4

The focus for this unit is 有什么打算? (What next?). Students consolidate their skills, knowledge and understandings through the study of the unit content. They extend and refine their communication skills in Chinese and gain a broader and deeper understanding of the language and culture. Elaboration of outcomes:

- **Reflecting on my life and planning my future:** Students reflect on their final year at school and their plans for the future: further education, employment and travel.
- **The environment:** Students explore current issues in relation to the environment in Chinese-speaking communities.
- **Current issues:** Students consider issues in the changing world relevant to them.

YEAR 11 and 12 Pathways

Course Information Handbook 2027

CHINESE: FIRST LANGUAGE ATAR COURSE

Prerequisites

A cultural and linguistic background in the language.

The Chinese first Language ATAR Course is designed for students with a cultural and linguistic background in Chinese. The course focuses on the interrelationship of language and culture, and further enhance the skills students possess to function in an increasingly globalised society and a culturally and linguistically diverse local community. Through engagement with the Chinese-speaking communities, locally and overseas, and through the study of themes and issues in personal, community and global perspectives, students strengthen their literacy skills in both Chinese and English languages.

Year 11 AECFL

UNIT 1

Relationships and human interactions are an introduction to text analysis and intercultural communication, with a focus on understanding how language features of texts support their communicative purposes. Students engage with texts to explore their culture-specific meaning.

UNIT 2

Communities in transition builds on students' knowledge about the communicative purpose of texts to raise their awareness of texts as a vehicle for conveying attitudes and values of text producers. Students examine the functions of cultural subtexts and their impact on intercultural communication.

Year 12 ATCFL

UNIT 3

Adapting to different cultures consolidates students' critical literacy skills for analysing language features that reflect text producers' identities and biases. Students examine the impact of language barriers on cross-cultural communication, with a view to identifying strategies for overcoming them.

UNIT 4

Sustainability issues further extend students' critical literacy skills for evaluating communication strategies used in texts to shape audience attitudes. Through examining language changes that have taken place through time and across geographical locations, students refine their skills for facilitating cross-cultural communication.

FRENCH: SECOND LANGUAGE ATAR COURSE

Prerequisites

B Grade or better in Year 10 French.

Year 11 AEFSL

UNIT 1

The focus for this unit is C'est la vie! (That's life!). Students build on their skills, knowledge and understandings through the study of the unit content. They further develop their communication skills in French and gain a broader insight into the language and culture. Elaboration of outcomes:

- **My life:** Students explore the relationships and interests in their lives. Students explore the topic from their own point of view or from the viewpoint of individuals from French-speaking communities.
- **Youth leisure activities:** Students investigate what young people in French-speaking communities do in their free time.
- **Leading a healthy lifestyle:** Students examine the importance of maintaining a healthy lifestyle and how the topic impacts the global community.

YEAR 11 and 12 Pathways

Course Information Handbook 2027

UNIT 2

The focus for this unit is Voyages (Travel). Students further develop their skills, knowledge and understandings through the study of the unit content. They extend their communication skills in French and gain a broader insight into the language and culture. Elaboration of outcomes:

- **My travel tales and plans:** Students explore holiday destinations for a future trip and recount their past holiday experiences. Students explore the topic from their own point of view or from the viewpoint of individuals from French-speaking communities.
- **Australia as a travel destination:** Students investigate Australia as a destination for travellers from French-speaking communities.
- **Travel in a modern world:** Students examine responsible travel. Students examine how the topic impacts the global community.

Year 12 ATFSL**UNIT 3**

The focus for this unit is Les médias (The media). Students expand their skills, knowledge and understandings through the study of the unit content. They extend and refine their communication skills in French and gain a broader and deeper understanding of the language and culture. Elaboration of outcomes:

- **Technology and me:** Students reflect on the role of technologies in their lives and in the lives of young people in French-speaking communities.
- **Film and music:** Students develop an insight into the cultures and lifestyles of the French-speaking communities through examples of francophone films, film clips and music.
- **In the media:** Students consider the media and its impact on the global community.

UNIT 4

The focus for this unit is Le monde qui nous entoure (The world around us). Students consolidate their skills, knowledge and understandings through the study of the unit content. They extend and refine their communication skills in French and gain a broader and deeper understanding of the language and culture. Elaboration of outcomes:

- **Planning my future:** Students reflect on their plans for the future.
- **Migrant experiences:** Students explore the accounts of French-speaking migrants to and from French-speaking communities, to consider reasons for migration, and experiences of participating in a new community.
- **Youth issues:** Students consider global youth issues related to coping with pressures: stress, drugs and alcohol.

ITALIAN: SECOND LANGUAGE ATAR COURSE**Prerequisites**

B Grade or better in Year 10 Italian.

Year 11 AEISL**UNIT 1**

The focus for this unit is Una vita da vivere (A life to live). Students build on their skills, knowledge and understandings through the study of the unit content. They further develop their communication skills in Italian and gain a broader insight into the language and culture. Elaboration of outcomes:

- **Amicizie e interessi personali (Personal friendships and interests):** Students explore relationships and interests in their own lives. Students explore the topic from their own point of view or from the viewpoint of individuals from Italian-speaking communities.
- **La vita italiana (Italian lifestyles):** Students investigate the lifestyles and interests of young Italians. Students investigate how the topic relates to groups in Italian-speaking communities.
- **Vivere nel mondo digitale (Living in a digital world):** Students examine the role of digital technologies in the lives of young people around the world. Students examine how the topic impacts the global community.

YEAR 11 and 12 Pathways

Course Information Handbook 2027

UNIT 2

The focus for this unit is Italia in primo piano (Italy up close). Students further develop their skills, knowledge and understandings through the study of the unit content. They extend their communication skills in Italian and gain a broader insight into the language and culture. Elaboration of outcomes:

- **Aspetti italiani (Italian aspects):** Students explore Italian aspects in their lives and in the community. Students explore the topic from their own point of view or from the viewpoint of individuals from Italian-speaking communities.
- **Eventi e feste (Events and festivals):** Students investigate Italian special events and festivals. Students investigate how the topic relates to groups in Italian-speaking communities.
- **Il contributo italiano (The Italian contribution):** Students examine the contribution of Italians in the areas of cuisine, the sciences and the arts. Students examine how the topic impacts the global community.

Year 12 ATISL**UNIT 3**

The focus for this unit is Grazie Italia (Thank you Italy). Students expand their skills, knowledge and understandings through the study of the unit content. They extend and refine their communication skills in Italian and gain a broader and deeper understanding of the language and culture. Elaboration of outcomes:

- **Cose italiane (All things Italian):** Students reflect on the place of things Italian in their lives and in their community.
- **La vita italiana (Italian lifestyle):** Students explore the lifestyle, interests and activities in the everyday life of Italians.
- **Il Made in Italy nel mondo (Il Made in Italy around the world):** Students consider Il Made in Italy as a global brand and explore the contribution of Italians.

UNIT 4

The focus for this unit is Ieri, oggi e domani (Yesterday, today and tomorrow). Students consolidate their skills, knowledge and understandings through the study of the unit content. They extend and refine their communication skills in Italian and gain a broader and deeper understanding of the language and culture. Elaboration of outcomes:

- **Riflettiamo sulla vita e pensiamo al futuro (Reflecting on my life and planning my future):** Students reflect on their final year at school and their plans for the future: further education, employment and travel.
- **I problemi dei giovani oggi (Youth issues):** Students explore employment, smoking and alcohol as issues for Italian youth.
- **I problemi ambientali (Environmental issues):** Students consider current global environmental issues in relation to climate change, that are relevant to them.

JAPANESE: SECOND LANGUAGE ATAR COURSE**Prerequisites**

B Grade or better in Year 10 Japanese.

Year 11 AEJSL**UNIT 1**

This unit focuses on 私の世界 (My world). Through the three topics – 家族と友達 (Family and friends), 学校生活 (School life) and つながり (Staying connected) – students further develop their communication skills in Japanese and gain a broader insight into the language and culture.

UNIT 2

This unit focuses on 若者たち (Young people). Through the three topics – 私の一日 (A day in my life), お祝いしましょう! (Let's celebrate!) and 世界に広がる日本文化 (Japanese culture in the world) – students extend their communication skills in Japanese and gain a broader insight into the language and culture.

YEAR 11 and 12 Pathways

Course Information Handbook 2027

Year 12 ATJSL

UNIT 3

The focus for this unit is わかい旅行者(りょこうしゃ) (Young travellers). Students expand their skills, knowledge and understandings through the study of the unit content. They extend and refine their communication skills in Japanese and gain a broader and deeper understanding of the language and culture.

UNIT 4

The focus for this unit is かこと未来(みらい) (Reflections and horizons). Students consolidate their skills, knowledge and understandings through the study of the unit content. They extend and refine their communication skills in Japanese and gain a broader and deeper understanding of the language and culture.

KOREAN: SECOND LANGUAGE ATAR COURSE

Prerequisites

B Grade or better in Year 10 Korean.

Year 11 AEKOR

UNIT 1

The focus for this unit is 일상생활 (Daily life). Students build on their skills, knowledge, and understandings through the study of the unit content. They further develop their communication skills in Korean and gain a broader insight into the language and culture.

Elaboration of outcomes:

- My daily routine: Students reflect on their family, home life, popular activities, and interests.
- School life: Students explore school life for young Korean speakers: rules, after school activities and preparing for life after graduation.
- Technology and social media: Students examine the role of technology and social media in the lives of young people around the world.

UNIT 2

The focus for this unit is 한국대중문화 (Korean popular culture). Students further develop their skills, knowledge, and understandings through the study of the unit content. They extend their communication skills in Korean and gain a broader insight into the language and culture. Elaboration of outcomes:

- **Korean music:** Students explore their likes and dislikes of Korean popular music and artists, and the meaning behind favourite song lyrics.
- **Korean film:** Students explore Korean films to develop an insight into the culture and lifestyles of the Korean-speaking communities.
- **The globalisation of Korean culture:** Students consider the contribution of Korean culture around the world through Korean brands and trends.

Year 12 ATKOR

The Year 12 syllabus is divided into two units which are delivered as a pair.

UNIT 3

This unit focuses on 여행 (Travel). Through the three topics – My travel plans, Cultural heritage, and Travelling today – students extend and refine their communication skills in Korean and gain a broader and deeper understanding of the language and culture.

UNIT 4

This unit focuses on 졸업 후 진로 (Life after school). Through the three topics – Planning my future, Studying and working in Korea, and Future plans – students extend and refine their communication skills in Korean and gain a broader and deeper understanding of the language and culture.

YEAR 11 and 12 Pathways

Course Information Handbook 2027

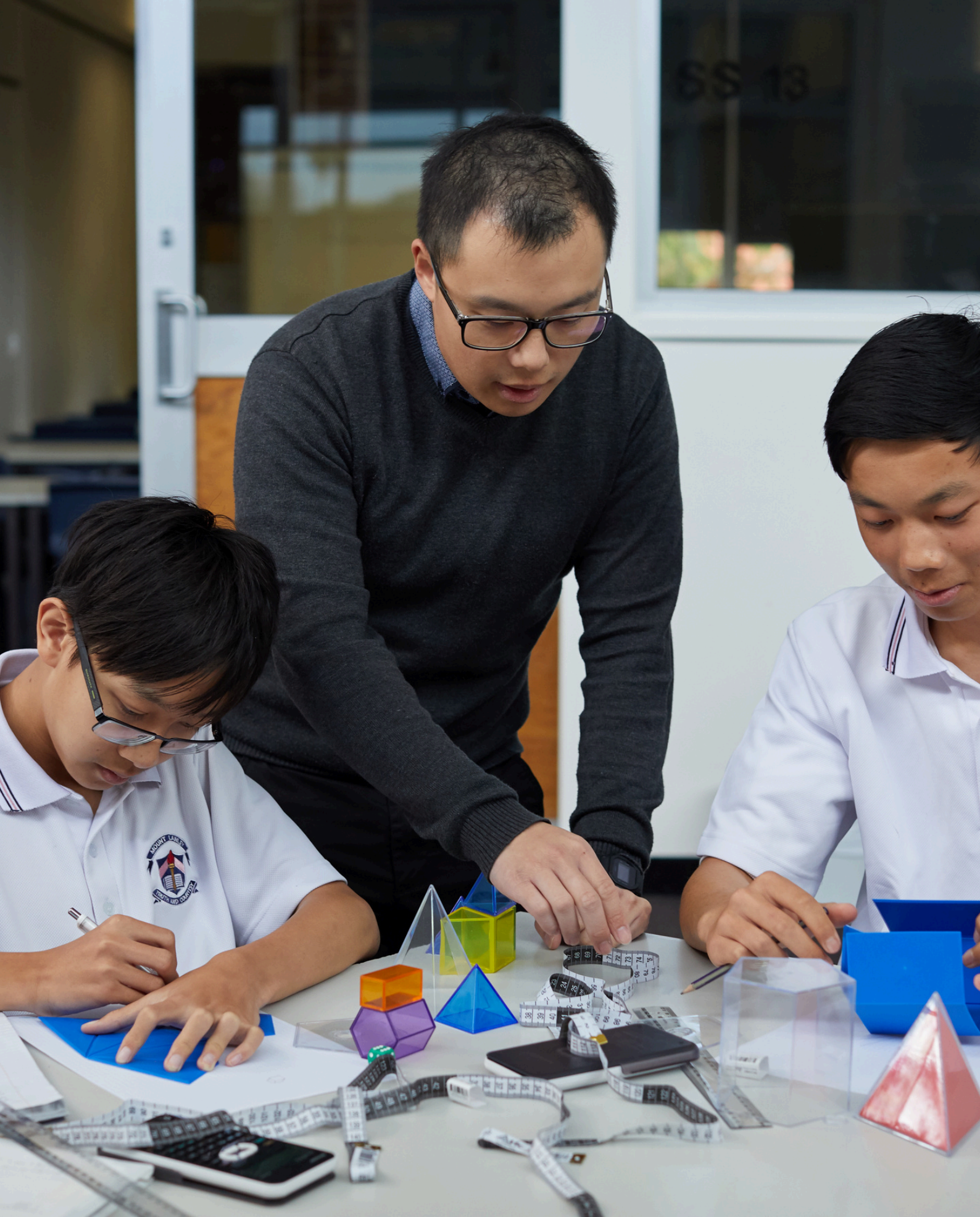

MATHEMATICS

MATHEMATICS

General Courses					
Year 11 (Unit 1 & 2)	Code	Cost	Year 12 (Unit 3 & 4)	Code	Cost
Mathematics Essentials	GEMAE	\$63	Mathematics Essentials	GTMAE	\$63
ATAR Courses					
Year 11 (Unit 1 & 2)	Code	Cost	Year 12 (Unit 3 & 4)	Code	Cost
Mathematics Applications	AEMAA	\$49	Mathematics Applications	ATMAA	\$49
Mathematics Methods	AEMAM	\$49	Mathematics Methods	ATMAM	\$49
Mathematics Specialist	AEMAS	\$68	Mathematics Specialist	ATMAS	\$68

*** Costs are estimates and are subject to change.**

You do not have to study mathematics in Senior School, but it is highly recommended that you do so. Most careers need mathematics and you should always choose the highest mathematics course that you can cope with that is not beyond your capabilities.

For students pursuing an ATAR pathway, the following options are permissible:

- Mathematics Methods and Mathematics Specialist
- Mathematics Methods and Mathematics Applications
- Mathematics Methods only
- Mathematics Applications only

The following are not allowed:

- Mathematics Specialist and Mathematics Applications
- Mathematics Specialist only

MATHEMATICS ESSENTIAL GENERAL COURSE

Prerequisites

None

Mathematics Essential is a non ATAR General course which focuses on using mathematics effectively, efficiently and critically to make informed decisions. It provides students with the mathematical knowledge, skills and understanding to solve problems in real contexts for a range of workplace, personal, further learning and community settings.

This course provides the opportunity for students to prepare for post-school options of employment and further training. We offer Mathematics Essential for students who are usually bound for a State Training Provider, further training or an occupation. There is no examination at the end of these general units so it does not score towards an ATAR. These are not 'easy' options and, there is a significant work-load involving major investigations and assessments where deadlines MUST be met. Students need to be well organised and committed to passing the course.

YEAR 11 and 12 Pathways

Course Information Handbook 2027

MATHEMATICS APPLICATIONS ATAR COURSE

Current Year 10 Course	Prerequisites
Year 10 Mathematics Academic Enrichment	All AE students are eligible.
Year 10 Mathematics Advanced	At least a Pathway C grade in Advanced pathway, if this is not met, recommendation for this course must be approved by the Program Coordinator.
Year 10 Mathematics Standard	At least a Pathway B grade in Standard Pathway, if this is not met, recommendation for this course must be approved by the Program Coordinator.

Mathematics Applications is an ATAR course which focuses on the use of mathematics to solve problems in contexts that involve financial modelling, graphical and network analysis, and growth and decay in sequences. It also provides opportunities for students to develop systematic strategies based on the statistical investigation process for answering questions that involve analysing univariate and bivariate data, including time series data.

The Mathematics Applications ATAR course is designed for students who want to extend their mathematical skills beyond Year 10, but whose future studies or employment pathways do not require knowledge of calculus. Students must recognise that this is a highly rigorous ATAR subject. Success relies heavily on established algebraic fluency, strong problem-solving skills, and a significant commitment to independent study. It is not an 'easy' ATAR option and requires a consistent work ethic to manage the fast-paced curriculum and demanding assessments. This course is designed for students who have a wide range of educational and employment aspirations, including continuing their studies at university (e.g. some business courses).

MATHEMATICS METHODS ATAR COURSE

Current Year 10 Course	Prerequisites
Year 10 Mathematics Academic Enrichment	All AE students are eligible.
Year 10 Mathematics Advanced	At least a Pathway B grade in Advanced Pathway, if this is not met, recommendation for this course must be approved by the Program Coordinator.

Mathematics Methods is an ATAR course which focuses on the use of calculus and statistical analysis. The study of calculus provides a basis for understanding rates of change in the physical world, and includes the use of functions, their derivatives and integrals, in modelling physical processes. The study of statistics develops students' ability to describe and analyse phenomena that involve uncertainty and variation. We offer Mathematics Methods to students who are strong at mathematics, whose future pathways may involve mathematics and statistics and their applications in a range of disciplines at university.

It is also advantageous for further studies in the health and social sciences. To be successful in this highly demanding subject, students must already possess exceptional algebraic fluency and a strong capacity for abstract reasoning. The fast-paced nature of this curriculum requires a substantial, ongoing commitment to independent study and daily practice to master complex mathematical concepts.

YEAR 11 and 12 Pathways

MATHEMATICS SPECIALIST ATAR COURSE

Current Year 10 Course	Prerequisites
Year 10 Mathematics Academic Enrichment	At least a Pathway C grade in AE pathway, if this is not met, recommendation for this course must be approved by the Program Coordinator.
Year 10 Mathematics Advanced	At least a Pathway A grade in Advanced pathway, if this is not met, recommendation for this course must be approved by the Program Coordinator.

Mathematics Specialist can **only** be taken in combination with Mathematics Methods. Mathematics Specialist is an ATAR course which provides opportunities, beyond those presented in the Mathematics Methods ATAR course, to develop rigorous mathematical arguments and proofs, and to use mathematical models more extensively. The Mathematics Specialist ATAR course contains topics in functions and calculus that build on and deepen the ideas presented in the Mathematics Methods ATAR course, as well as demonstrate their application in many areas. This course also extends understanding and knowledge of statistics and introduces the topics of vectors, complex numbers and matrices.

The Mathematics Specialist ATAR course is the only ATAR mathematics course that cannot be taken as a stand-alone course. We offer the double course choice for students who are strong at mathematics and may be pursuing studies at tertiary level that involve the high profile sciences and mathematics (e.g. engineering). Because this is the most advanced mathematics pathway, success requires not only exceptional mathematical ability but also a relentless work ethic and enjoyment in mathematics. Students must be highly proficient in constructing formal proofs and possess the superior time-management skills required to balance the intensive, compounding workload of two highly rigorous ATAR mathematics courses.

MATHEMATICS PATHWAYS FLOWCHART

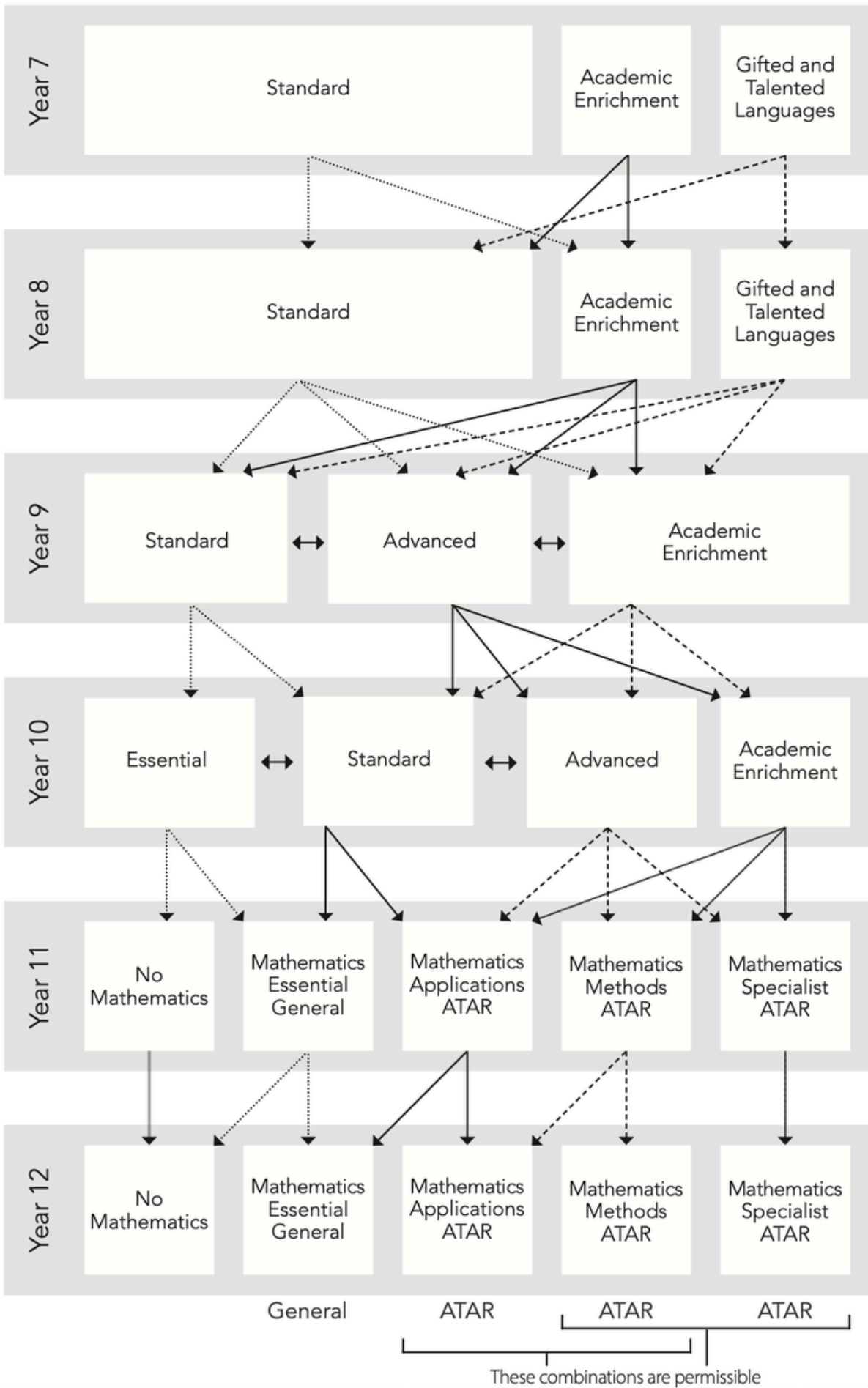

YEAR 11 and 12 Pathways



SCIENCE

General Courses					
Year 11 (Unit 1 & 2)	Code	Cost	Year 12 (Unit 3 & 4)	Code	Cost
Human Biology	GEHBY	\$33	Human Biology	GTHBY	\$33
Science in Practice	GESIP	\$57	Science in Practice	GTSIP	\$57
ATAR Courses					
Year 11 (Unit 1 & 2)	Code	Cost	Year 12 (Unit 3 & 4)	Code	Cost
Biology	AEBLY	\$46	Biology	ATBLY	\$46
Chemistry	AECHE	\$30	Chemistry	ATCHE	\$30
Human Biology	AEHBY	\$60	Human Biology	ATHBY	\$60
Physics	AEPHY	\$30	Physics	ATPHY	\$30

* Costs are estimates and are subject to change.

HUMAN BIOLOGY GENERAL COURSE

Prerequisites

None

Year 11 GEHBY

UNIT 1 – BODY CELLS

This unit focuses on the nutritional choices that we make for the optimal functioning of body cells. Students investigate and model cell processes through practical activities. They explore the digestive and musculoskeletal systems through real and virtual dissections. Students analyse and evaluate various diets against the Australian Dietary Guidelines.

UNIT 2 – HEALTHY BODY SYSTEMS

The focus of this unit is on the importance of regular health checks to prevent or manage medical problems. Students investigate blood pressure, heart rate, bloody oxygen levels and lung capacity through practical activities. They explore the systems of the body through real and virtual dissections. Students analyse data from blood and urine samples to detect anomalies.

Year 12 GTHBY

UNIT 3 – PERSONAL REPRODUCTIVE HEALTH

This unit explores how the male and female reproductive systems are specialised for successful fertilisation and implantation, and the development of the embryo and foetus. It also explores how lifestyle choices can impact personal reproductive health, fertility and the delivery of a healthy baby. Contraceptive methods and assisted reproductive technologies are also explored.

UNIT 4 – IMMUNE SYSTEM AND INFECTIOUS DISEASE

This unit explores the causes and spread of disease and how humans respond to invading pathogens. It also explores the importance of coordinated community and global responses for the prevention and control of infectious disease transmission.

YEAR 11 and 12 Pathways

Course Information Handbook 2027

SCIENCE IN PRACTICE GENERAL COURSE

Prerequisites

None

Year 11 GESIP

UNIT 1

This unit allows students to explore, investigate and model processes through practical activities. Students are encouraged to use information and communication technology to gather and interpret data, and communicate findings in a variety of ways. Contexts form a framework that enables students to actively engage in inquiry-based learning and further develop their understanding of scientific concepts. Students will study the context of Forensic Science during Unit 1.

UNIT 2

Please refer to the GESIP Unit 1 description and contexts. Students will study the context of Wheels in Motion during Unit 2.

Year 12 GTSIP

UNIT 3

Please refer to the GESIP UNIT 1 for the description of this unit. Students will study the context of Acids and Bases during Unit 3.

UNIT 4

Please refer to the GESIP UNIT 1 for the description of this unit. Students will study the context of Rocketry during Unit 4.

BIOLOGY ATAR COURSE

Prerequisites

Students wishing to study ATAR Biology must achieve an A or B GRADE in Year 10 Science, and a minimum of 65% in the Genetics section of the Year 10 course.

Students not satisfying the prerequisites, and wishing to attempt courses for which they have not been recommended, MUST seek an interview with the Science Program Coordinator.

Year 11 AEBLY

UNIT 1 – ECOSYSTEMS AND BIODIVERSITY

Students investigate and describe a number of diverse ecosystems, exploring the range of biotic and abiotic components to understand the dynamics, diversity and underlying unity of these systems. Students develop an understanding of the processes involved in the movement of energy and matter in ecosystems; they investigate ecosystem dynamics. They also investigate how measurement of abiotic factors can form the basis for spatial and temporal comparisons between ecosystems. Students use classification keys to identify organisms and will be involved in fieldwork as part of this unit.

UNIT 2 – FROM SINGLE CELLS TO MULTICELLULAR ORGANISMS

Students investigate the way in which matter moves and energy is transformed and transferred in the processes of photosynthesis and respiration, and the role of enzymes in controlling biochemical systems. Students use science inquiry skills to explore the relationship between structure and function, by conducting dissections and microscopic examination.

Year 12 ATBLY

UNIT 3 – CONTINUITY OF SPECIES

Students investigate mechanisms of heredity and the ways in which inheritance patterns can be explained, modelled and predicted; they connect these patterns to population dynamics and apply the theory of evolution by natural selection in order to examine changes in populations.

UNIT 4 – SURVIVING IN A CHANGING ENVIRONMENT

Students investigate system change and continuity in response to changing external conditions and pathogens; they investigate homeostasis and the transmission and impact of infectious disease; and they consider the factors that encourage or reduce the spread of infectious disease at the population level.

YEAR 11 and 12 Pathways

Course Information Handbook 2027

CHEMISTRY ATAR COURSE

Prerequisites

Students wishing to study ATAR Chemistry must achieve an A or B grade in Year 10 Science AND achieve a minimum of 65% in the Chemistry section of the Year 10 course.

Students must also have an ATAR Mathematics recommendation from their Maths teacher and must be recommended for the course by their Science teacher. Students not satisfying the prerequisites, and wishing to attempt courses for which they have not been recommended, MUST seek an interview with the Science Program Coordinator.

Year 11 AECHE

UNIT 1 – CHEMICAL FUNDAMENTALS: STRUCTURE, PROPERTIES AND REACTIONS

Students use the models of atomic structure and bonding to explain the macroscopic properties of materials. Students develop their understanding of the energy changes associated with chemical reactions and the use of chemical equations to calculate the masses of substances involved in chemical reactions.

UNIT 2 – MOLECULAR INTERACTIONS AND REACTIONS

Students continue to develop their understanding of bonding materials and the relationship between structure, properties and reactions, including factors that affect the rate of chemical reactions. Students investigate the properties of water and acids and bases, and use chemical equations to calculate the concentrations and volumes of solutions involved in reactions.

(continued from previous page)

Year 12 ATCHE

UNIT 3 – EQUILIBRIUM, ACIDS AND BASES, AND REDOX REACTIONS

Students investigate the concept of reversibility of reactions and the dynamic nature of equilibrium in chemical systems; contemporary models of acid-base behaviour that explain their properties and uses; and the principals of oxidation and reduction reactions, including the generation of electricity from electrochemical cells.

UNIT 4 – ORGANIC CHEMISTRY AND CHEMICAL SYNTHESIS

Students develop their understanding of the relationship between structure, properties and chemical reactions of different organic functional groups. Students also investigate the process of chemical synthesis, to form useful substances and products. Students also consider a range of factors in the design of chemical synthesis processes.

HUMAN BIOLOGY ATAR COURSE

Prerequisites

Students wishing to study ATAR Human Biology MUST achieve an A or B grade in Year 10 Science and a minimum of 65% in the Genetics section of the Year 10 course. Students must also have the recommendation of their Science teacher.

Students not satisfying the prerequisites, and wishing to attempt courses for which they have not been recommended, MUST seek an interview with the Science Program Coordinator.

Year 11 AEHBY

UNIT 1 – THE FUNCTIONING HUMAN BODY

Students look at how human structure and function supports cellular metabolism and how lifestyle choices affect body functioning. Students investigate cells and explore the respiratory, circulatory, digestive and excretory systems of the human body, and investigate questions about problems associated with factors affecting metabolism.

YEAR 11 and 12 Pathways

Course Information Handbook 2027

UNIT 2 – REPRODUCTION AND INHERITANCE

Students study the reproductive systems of males and females, the mechanisms of the transmission of genetic material from generation to generation. Students will also investigate the effects of the environment on gene expression.

Year 12 ATHBY**UNIT 3 – HOMEOSTASIS AND DISEASE**

Students investigate the nervous and endocrine systems and the mechanisms that help maintain the systems of the body to function within normal range, and the body's immune responses to invading pathogens.

UNIT 4 – HUMAN VARIATION AND EVOLUTION

Students will investigate variation in humans, their changing environment and evolutionary trends in hominoids. Students explore variations in characteristics, how gene pools are affected by evolutionary mechanisms, and evolutionary changes in gene pools.

PHYSICS ATAR COURSE**Prerequisites**

Students wishing to study ATAR Physics must achieve an "A" or "B" grade in Year 10 Science AND achieve a minimum of 70% in the Physics section in the Year 10 course.

Students must also have an ATAR Mathematics recommendation (preferably ATAR Mathematics Methods) from the Program Coordinator - Maths and must be recommended by the Program Coordinator - Science. Students not satisfying the prerequisites, and wishing to attempt courses for which they have not been recommended, MUST seek an interview the Program Coordinator - Science.

Year 11 AEPHY**UNIT 1 – MOTION, FORCES AND ENERGY**

Students develop an understanding of motion, forces, and mechanical and thermal energy, which can be used to describe, explain and predict a wide range of phenomena. Students describe linear motion in terms of position and time data, and examine the relationships between force, momentum and energy for interactions in one dimension.

UNIT 2 – WAVES, NUCLEAR AND ELECTRICAL PHYSICS

Students explore the ways physics is used to describe, explain and predict the energy transfers and transformations that are pivotal to modern industrial societies. Students investigate common wave phenomena in various media. They apply the nuclear model of the atom to investigate radioactivity and learn how nuclear reactions convert mass into energy. Students examine the movement of electrical charge in circuits and use this to analyse, explain and predict electrical phenomena.

Year 12 ATPHY**UNIT 3 – GRAVITY AND RELATIVITY**

Students investigate models of motion in gravitational, electric, magnetic fields to explain how forces act at a distance. They examine the theory of special relativity and the consequences of general relativity.

UNIT 4 – ELECTROMAGNETISM AND MODERN PHYSICS

Students use the theory of electromagnetism to explain the production and propagation of electromagnetic waves and investigate how shortcomings in existing theories led to the development of the quantum theory of light and matter.

YEAR 11 and 12 Pathways



TECHNOLOGIES

TECHNOLOGIES

	Year 11 (Unit 1 & 2)	Code	Cost	Year 12 (Unit 3 & 4)	Code	Cost
COMPUTING	General Courses					
	Applied Information Technology	GEAIT	\$60	Applied Information Technology	GEAIT	\$60
	Computer Science	GECS	\$60	Computer Science	GECS	\$60
	ATAR Courses					
	Computer Science	AESCS	\$60	Computer Science	ATCSC	\$60
DESIGN & TECHNOLOGY	General Courses					
	Engineering Studies	GEEST	\$180	Engineering Studies	GTEST	\$180
	Design (Dimensional Design)	GEDES	\$130	Design (Dimensional Design)	GTDES	\$130
	Materials, Design & Technology (Wood)	GEMDTW	\$190	Materials, Design & Technology (Wood)	GTMDTW	\$190
	ATAR Courses					
	Engineering Studies	AEEST	\$95	Engineering Studies	ATEST	\$95
	Certificate Qualifications (2 Year Delivery)					
	Year 11			Year 12		
	Certificate II in Engineering Pathways MEM20422 (course begins)		\$180	Certificate II in Engineering Pathways MEM20422 (course continues)		\$180
	Certificate II in Visual Arts (Photography) CUA20720 (course begins)		\$130	Certificate II in Visual Arts (Photography) CUA20720 (course continues)		\$130
HOME ECONOMICS	General Courses					
	Children, Family & the Community	GECFC	\$120	Children, Family & the Community	GTCFC	\$120
	Food Science and Technology	GEFST	\$325	Food Science and Technology	GTFST	\$325
	Certificate Qualifications (2 Year Delivery)					
	Year 11 Certificate II in Hospitality SIT20316 (course begins)		\$325	Year 12 Certificate II in Hospitality SIT20316 (course continues)		\$325

* Costs are estimates and are subject to change.

COMPUTING

APPLIED INFORMATION TECHNOLOGY GENERAL COURSE

Prerequisites

None

The Applied Information Technology General course provides students with the knowledge and skills to use a range of computer hardware and software to create, manipulate and communicate information in an effective, responsible and informed manner. Students develop an understanding of computer systems; the management of data; and the use a variety of software applications to investigate, design, construct and evaluate digital products and digital solutions. The course offers pathways to further studies and a range of technology-based careers and a set of skills that equip students for the 21st century and give them an appreciation of the impact of information technology on society.

Year 11 GEAIT

UNIT 1 – PERSONAL COMMUNICATION

The focus of this unit is to enable students to use technology to meet personal needs. Students develop a range of skills that enable them to communicate using appropriate technologies and to gain knowledge that assists in communicating within a personal context.

UNIT 2 – WORKING WITH OTHERS

The focus of this unit is to enable students to use a variety of technologies to investigate managing data, common software applications and wireless network components required to effectively operate within a small business environment. They examine the legal, ethical and social impacts of technology within society.

Year 12 GTAIT

UNIT 3 – MEDIA INFORMATION AND COMMUNICATION TECHNOLOGIES

The emphasis of this unit is on the use of digital technologies to create and manipulate digital media. Students use a range of applications to create visual and audio communications. They examine trends in digital media transmissions and implications arising from the use of these technologies.

UNIT 4 – DIGITAL TECHNOLOGIES IN BUSINESS

The emphasis of this unit is on the skills, principles and practices associated with various types of documents and communications. Students identify the components and configuration of networks to meet the needs of a business. Students design digital solutions for clients, being mindful of the various impacts of technologies within legal, ethical and social boundaries.

COMPUTING

COMPUTER SCIENCE GENERAL COURSE

Prerequisites

None

In the Computer Science General Course students are introduced to the fundamental principles, concepts and skills within the field of computing. They learn how to diagnose and solve problems while exploring the building blocks of computing. Students explore the principles related to the creation of computer and information systems; software development; the connectivity between computers; the management of data; the development of database systems; and the moral and ethical considerations for the use of computer systems. This course provides students with the practical and technical skills that equip them to function effectively in a world where these attributes are vital for employability and daily life in a technological society.

YEAR 11 and 12 Pathways

Course Information Handbook 2027

Year 11 GECSC**UNIT 1 – PERSONAL USE OF COMPUTER SYSTEMS**

This unit provides students with the knowledge and skills required to use and maintain a personal computer. It introduces a formal method for developing simple information systems and databases. While considering personal needs, students examine the social, ethical and legal implications of personal computer use.

UNIT 2 – PERSONAL USE OF COMMUNICATION AND INFORMATION SYSTEMS

This unit introduces a formal method for developing networks and internet technologies and writing a sequence of simple instructions. Students examine the social, ethical and legal implications associated with software development.

Year 12 GTCSC**UNIT 3 – DEVELOPING COMPUTER-BASED SYSTEMS AND PRODUCING SPREADSHEET AND DATABASE SOLUTIONS**

The focus for this unit is on developing computer-based systems and producing spreadsheet and database solutions. Students are introduced to the internal, interrelating components of computer-based systems in an industry context. They examine a variety of systems, build on their spreadsheet and database skills and gain an appreciation of how these concepts and technologies are used in industry.

UNIT 4 – DEVELOPING COMPUTER-BASED SOLUTIONS AND COMMUNICATIONS

The focus for this unit is on developing computer-based systems solutions and communications. Students are introduced to networking concepts, as applied to industry. Through the use of algorithms, students develop programming skills. Students create solutions exploring the ethical, legal and societal implications of industry-based applications.

COMPUTING

COMPUTER SCIENCE ATAR COURSE

Prerequisites

Students who study this course will be on an an ATAR pathway with an average of at least 60% across all subjects in Year 10.

This Computer Science ATAR course focuses on building key skills and knowledge that apply to computer systems and software. Students will disassemble and reassemble computers, install operating systems and subsequent applications. They will then network these computers, both wired and wireless, to a server to learn security strengths of access control and authentication. On the same computers the students will create databases that meet business expectations and code to create programs to provide solutions to common problems expected in the workforce today.

Students will apply this knowledge and these skills to have a greater understanding of the link between hardware components and how computing software is made. A broad understanding of systems thinking is also learned.

Year 11 AECSC**UNIT 1 – DEVELOPING COMPUTER-BASED SYSTEMS AND PRODUCING SPREADSHEET AND DATABASE SOLUTIONS**

The focus for this unit is developing computer-based systems, and producing spreadsheets, and database solutions. Students are introduced to the internal, interrelating components of computer-based systems in an industry context. They examine a variety of systems, build on their spreadsheet and database skills and gain an appreciation of how these concepts and technologies are used in industry.

YEAR 11 and 12 Pathways

UNIT 2 – DEVELOPING COMPUTER-BASED SYSTEMS SOLUTIONS AND COMMUNICATIONS

The focus for this unit is developing computer-based systems solutions and communications. Students are introduced to networking concepts, as applied to industry. Through the use of algorithms, students develop programming skills. They create solutions exploring the ethical, legal and societal implications of industry-based applications.

Year 12 ATCSC**UNIT 3 – DESIGN AND DEVELOPMENT OF COMPUTER-BASED SYSTEMS AND DATABASE SOLUTIONS**

In this unit, students understand the design concepts and tools used to develop relational database systems. They consider the complex interactions between users, developers, the law, ethics and society when computer systems are used and developed.

UNIT 4 – DESIGN AND DEVELOPMENT OF COMMUNICATION SYSTEMS AND SOFTWARE SOLUTIONS

In this unit, students gain the knowledge and skills to create software. They use algorithms and structured programming to design and implement software solutions for a range of problems using the Software Development Cycle. Students examine attitudes and values that lead to the creation and use of computer-based systems and their effect on society. Students consider networks, communication systems, including security and protocols.

DESIGN & TECHNOLOGY

ENGINEERING STUDIES GENERAL COURSE

Prerequisites

None

The Engineering Studies General course provides opportunities for students to investigate, research and present information, design and make products and undertake project development. These opportunities allow students to apply engineering processes, understand underpinning scientific and mathematical principles, develop engineering technology skills and explore the interrelationships between engineering and society. This course is essentially a practical course focusing on real-life contexts. It aims to prepare students for a future in an increasingly technological world, by providing the foundation for life-long learning about engineering. It is particularly suited to those students who are interested in engineering and technical industries as future careers.

Year 11 GEEST**UNIT 1 – ENGINEERING DESIGN PROCESS**

In this unit, students develop an understanding of the engineering design process. They study and interpret a given design brief, learn a range of research skills and devising methods to develop concepts, then plan and communicate proposed solutions to the given design brief. They study core engineering theory and relevant theory of their chosen specialist area, and learn to integrate and use this knowledge to develop and present proposals for practical solutions. Students calculate requirements, prepare drawings and produce lists of materials and components and then follow a given timeline to produce, test and evaluate the finished product.

UNIT 2 – AUTOMATION AND TECHNICAL INNOVATION

In this unit, students focus on the topics of automation and technical innovation. They investigate engineering examples within these themes and the impact these technologies have on society. Students study and interpret a given design brief. They develop responses to the brief through a process that requires them to engage in a range of activities including: researching similar existing engineered products; sketching, drawing and annotating concepts; and choosing the preferred concept for production as a prototype or working model. Students finalise their chosen design by documenting its specifications in the form of appropriate drawings and lists of materials and components. They follow a given timeline to undertake tasks required to produce, test, and evaluate the product. Core and specialist area theory continues to be studied to forge greater understanding of the scientific, mathematical and technical concepts that explain how engineered products function.

YEAR 11 and 12 Pathways

Course Information Handbook 2027

Year 12 GTEST**UNIT 3 – MECHANICAL ENGINEERING IN SOCIETY**

In the development of an engineering project, students study core engineering theory and theory in their chosen specialist area. They develop an understanding of the different forms of energy, uses of these different forms and sources of renewable and non-renewable energy.

In this unit, students also develop a greater understanding of the engineering design process and learn and apply more complex theory and understanding to a student developed design brief. Given guidelines and a context, students develop and respond to the design brief, through a process that requires them to investigate existing products, construction materials and components. Design ideas are developed through annotated sketches and concept drawings. Students select and analyse the most suitable concept for production as a prototype or working model. Students finalise their chosen design by documenting its specifications in the form of appropriate orthographic drawings and lists of materials and components. They calculate the cost of the prototype or model. They then follow a given timeline to undertake the tasks required to produce, test and evaluate the product.

UNIT 4 – DEVELOPMENT OF A MECHANICAL ENGINEERING DESIGN SOLUTION

In this unit, students develop their understanding of core and specialist area theory to better understand the scientific, mathematical and technical concepts that explain how engineered products function. They study the impact of the different forms of obsolescence in engineering products on society, business and the environment. Students refine their understanding of the engineering design process. Students develop a design brief and respond to the brief through a process that requires them to engage in a range of activities, and investigate construction constraints, materials and components. Design ideas are developed through annotated sketches and concept drawings. Students select and analyse the most suitable concept for production as a prototype or working model.

DESIGN & TECHNOLOGY**DESIGN (DIMENSIONAL DESIGN) GENERAL COURSE****Prerequisites**

None

The goals of the Design General course are to facilitate a deeper understanding of how design works; and how ideas, beliefs, values, attitudes, messages and information are effectively communicated to specific audiences with specific intentions or purposes via visual media forms. This course aims to achieve these goals by exposing students to a variety of communication forms and a thorough exploration of design.

Design projects allow students to demonstrate their skills, techniques and application of design principles and processes; to analyse problems and possibilities; and to devise innovative strategies within design contexts.

There is potential for students to develop transferable skills and vocational competencies while devising innovative designs. In this course, students develop a competitive edge for current and future industry and employment markets. This course also emphasises the scope of design in professional and trade based industries allowing students to maximise vocational and/or university pathways.

Year 11 GEDES**UNIT 1 – DESIGN FUNDAMENTALS**

The focus of this unit is to introduce design process and practice. Students learn that design can be used to provide solutions to design problems and communication needs. They are introduced to basic design skills and a range of techniques within a defined context to demonstrate control over the elements and principles of design. Dimensional Design: a series of small design tasks exploring the elements and principles of design resulting in 3D jewellery pieces from found and recycled materials, design and produce a simple felted toy or hat, new age chess set, 3D educational resource aimed at teaching about the elements and principles to a young child, alphabet blocks.

YEAR 11 and 12 Pathways

Course Information Handbook 2027

UNIT 2 – PERSONAL DESIGN

The focus of this unit is personal design. Students learn that they visually communicate aspects of their personality, values and beliefs through their affiliations and their manipulation of personal surroundings and environments. Students explore design elements and principles and the design process in a project communicating something of themselves. Students increase familiarity with basic production skills and processes, materials and technologies. Dimensional Design: personalised t-shirt design, my costume or costume design for a dress up day at school, personal jewellery set, accessories, re-designing my dream room, including model making and mood board or swatching.

Year 12 GTDES**UNIT 3 – PRODUCT DESIGN**

The focus of this unit is product design. Students learn that the commercial world is comprised of companies, requiring consumer products, services and brands for a particular audience. They are introduced to the concept of intellectual property. Using the design process, they create products/services, visuals and/or layouts with an awareness of codes and conventions. They use relevant and appropriate production skills and processes, materials and technologies relevant to the design.

UNIT 4 – CULTURAL DESIGN

The focus of this unit is cultural design. Students learn that society is made up of different groups of people who share diverse values, attitudes, beliefs, behaviours and needs, and that different forms of visual communication transmit these values and beliefs. Students are encouraged to create designs that link to a culture or sub-culture and are introduced to ethical issues concerning representation. Students develop a design process with an understanding of codes and conventions. They consider communication strategies and audience. They define and establish contemporary production skills and processes, materials and technologies.

DESIGN & TECHNOLOGY**MATERIALS, DESIGN & TECHNOLOGY (WOOD) GENERAL COURSE****Prerequisites****None**

The Materials Design and Technology General course is a practical course. The course allows students to explore and use materials in the learning context of wood with the design and manufacture of products as the major focus. There is also the flexibility to incorporate additional materials from outside the designated context. This will enhance and complement the knowledge and skills developed within the course as many modern-day products are manufactured using a range of different material types.

Students examine social and cultural values and the short-term and long-term impacts of the use and misuse of materials and associated technologies. Through this inquiry, experimentation and research, students develop their creativity and understanding of the society in which they live.

Working with materials, students develop a range of manipulation, processing, manufacturing and organisational skills. When designing with materials, they develop cognitive skills, such as solving problems, generating ideas, creative design strategies and communicating what they do. This makes them more technologically literate and, as consumers, enables them to make more informed decisions about the use and misuse of technology. The Materials Design and Technology General course aims to prepare all students for a future in a technological and material world by providing the foundation for lifelong learning about how products are designed and how materials are developed and used.

Year 11 GEMDTW**UNIT 1**

Students interact with a variety of items that have been specifically designed to meet certain needs. Students are introduced to the fundamentals of design. They learn to communicate various aspects of the technology process by constructing what they design. Throughout the process, students learn about the origins, classifications, properties and suitability for purpose of the materials they are using, and are introduced to a range of production equipment and techniques. They develop materials manipulation skills and production management strategies, and are given the opportunity to realise their design ideas through the production of their design project.

YEAR 11 and 12 Pathways

Course Information Handbook 2027

UNIT 2

Students interact with products designed for a specific market. They use a range of techniques to gather information about existing products and apply the fundamentals of design. Students learn to conceptualise and communicate their ideas and various aspects of the design process within the context of constructing what they design.

Throughout the process, students learn about the origins, classifications, properties and suitability for end use of materials they are working with.

(continued from previous page)

Students are introduced to a range of technology skills and are encouraged to generate ideas and realise them through the production of their design projects. They work within a defined environment and learn to use a variety of relevant technologies safely and effectively. Students, in consultation with teachers, select projects of interest and then design and make products suitable for a specific market.

Year 12 GTMDTW**UNIT 3**

Students develop an understanding of the elements and fundamentals of design and consider human factors involved in the design, production and use of their projects. They develop creative thinking strategies and work on design projects within specified constraints. Students learn about the classification and properties of a variety of materials and make appropriate materials selection for design needs.

Students learn about manufacturing and production skills and techniques. They develop the skills and techniques appropriate to the materials being used and gain practice in planning and managing processes through the production of design project. They learn about risk management and ongoing evaluation processes.

Unit 4

Students learn about the nature of designing for a client, target audience or market. Students apply an understanding of the elements and fundamentals of design and consider human factors involved in their design projects. Students learn about the nature, properties and environmental impacts related to a variety of materials and production techniques. They develop creative thinking strategies, work on design projects within specified constraints and consider the environmental impacts of recycling of materials. Students extend their understanding of safe working practices and contemporary manufacturing techniques and develop the knowledge, understanding and skills required to manage the processes of designing and manufacturing.

DESIGN & TECHNOLOGY ENGINEERING STUDIES ATAR COURSE

Prerequisites

Students who study this course will have achieved a 65% average across all Year 10 subjects. This is a demanding course. Students should also select Methods, Physics or Chemistry.

NOTE: In 2027 these classes may have a Period 0, starting at 7:35 am.

This is a compulsory part of the course.

The Engineering Studies ATAR course provides opportunities for students to investigate, research and present information, design and make products and undertake project development. These opportunities allow students to apply engineering processes, understand underpinning scientific and mathematical principles, develop engineering technology skills and explore the interrelationships between engineering and society.

The Engineering Studies ATAR course is essentially a practical course focusing on real-life contexts. It aims to prepare students for a future in an increasingly technological world by providing the foundation for life-long learning about engineering. It is particularly suited to those students who are interested in engineering and technical industries as future careers.

YEAR 11 and 12 Pathways

Course Information Handbook 2027

Year 11 AEEST**UNIT 1**

In the development of an engineering project, students study core engineering theory and their chosen specialist area theory. They develop an understanding of different forms of energy, uses of these different forms, and sources of renewable and non-renewable energy. Given guidelines and a context, students apply their knowledge of the engineering design process and theory to develop and respond to a design brief. This requires them to investigate existing products, construction materials and components.

Design ideas are developed through annotated sketches and concept drawings. Students then select and analyse the most suitable concept for production as a prototype or working model. Students finalise their chosen design by documenting its specifications in the form of appropriate orthographic drawings, specialist diagram and lists of materials and components. They calculate the cost of the prototype or model. They follow a given timeline to undertake tasks required to produce, test and evaluate the product.

UNIT 2

This unit develops students' understanding of core and specialist area theory to better understand the scientific, mathematical and technical concepts that explain how engineered products function. They study the impact of the different forms of obsolescence in engineering products on society, business and the environment.

Students continue to refine their understanding and skills of the engineering design process, undertaking tasks to produce, test and evaluate the product. Core and specialist area theory continues to be studied to forge greater understanding of the scientific, mathematical and technical concepts that explain how engineered products function.

Year 12 ATEST**UNIT 3**

In this unit, students develop their understanding of core and specialist area theory. They also study the impacts of obtaining and using the different forms of renewable and nonrenewable energy on society, business and the environment. Students use the engineering design process beginning with the development of a comprehensive design brief that has a focus on a problem, need or opportunity.

They synthesise responses to the brief by engaging in a range of activities that include: detailed research of similar existing engineered products; construction materials and components; sketching, drawing and notating concepts; analysing and justifying the choice of the most promising of these for production as a prototype or working model. Students refine their understanding and skills of the engineering design process, undertaking tasks to produce, test and evaluate the product.

UNIT 4

In this unit, students consider and analyse the stages within the life cycle of engineering products. Students develop and demonstrate an understanding of the impacts on society, business and the environment that occur during the life cycle of engineered products. Students continue to refine their understanding and skills of the engineering design process, undertaking tasks to produce, test and evaluate the product. Core and specialist area theory continues to be studied to forge greater understanding of the scientific, mathematical and technical concepts that explain how engineered products function.

HOME ECONOMICS**CHILDREN, FAMILY AND THE COMMUNITY GENERAL****Prerequisites****None**

The Children, Family and the Community General course focuses on factors that influence human development and the wellbeing of individuals, families and communities. Students explore the health of individuals and communities and the protective and preventative strategies that impact on growth and development. They engage in shared research, examine goal setting, self-management, decision making, communication and cooperation skills when creating products, services or systems that will assist individuals, families and communities to achieve their needs and wants. Contemporary Australian issues or trends relating to families and communities at the state and national level are examined in practical ways. The content is focused around; nutrition, family structure, teenage issues, communication, community resources, careers and employment, workplace laws, influence of advertising and media, exercise and physical activity, stress management, role models and a range of practical skills.

YEAR 11 and 12 Pathways

Course Information Handbook 2027

Year 11 GECFC**UNIT 1 – FAMILIES AND RELATIONSHIPS**

This unit focuses on family uniqueness. Students examine the role of families and the relationships between individuals, families and their communities. Through an understanding of growth and development, students recognise the characteristics of individuals and families and that development is affected by biological and environmental influences.

They identify roles and responsibilities of families, and examine their similarities and differences, the issues that arise from family interactions and the influence of attitudes, beliefs and values on the allocation of resources to meet needs and wants. Students make decisions, examine consequences and develop skills to accommodate actions that impact themselves or others. Skills, processes, understandings and knowledge are developed through individual and group experiences. Students design and produce products and services that meet the needs of individuals, families and communities.

UNIT 2 – OUR COMMUNITY

This unit focuses on families, relationships and living in communities. The influence of biological and environmental factors, lifestyle behaviours and health status on growth and development is studied. Students explore the health of individuals and communities and the protective and preventative strategies that impact on growth and development. Students examine the roles and responsibilities of particular groups, networks, and services, and the impact of attitudes, beliefs and values on the management of resources. Students engage in shared research practice, communicate information, use decision-making, goal setting, self-management and cooperation skills when creating products, services or systems that will assist individuals, families and communities to achieve their needs and wants.

Year 12 GTCFC**UNIT 3 – BUILDING ON RELATIONSHIPS**

In this unit, students investigate the principles of development and how these relate to the domains and theories of development. Students examine and evaluate the features of products, services and systems for individuals and families. They examine the diverse and dynamic nature of families in Australia. They recognise and acknowledge cultural diversity, and inequity and injustice issues.

Students develop effective self-management and interpersonal skills to recognise and enhance personal relationships, enabling them to take active roles in society.

UNIT 4 – MY PLACE IN THE COMMUNITY

In this unit, students examine the effect on an individual's development and wellbeing in a society characterised by rapid change. They explore contemporary Australian issues or trends relating to families and communities at the state and national level and are introduced to a range of advocacy types.

Students examine developmental theories and their influence on cognitive development. Students use effective self-management and interpersonal skills when developing or assessing products, processes, services, systems or environments.

HOME ECONOMICS

FOOD SCIENCE AND TECHNOLOGY GENERAL

Prerequisites**None**

The Food Science and Technology General course provides opportunities for students to explore and develop food-related interests and skills. Food impacts on every aspect of daily life and is essential for maintaining overall health and wellbeing. Students organise, implement and manage production processes in a range of food environments and understand systems that regulate food availability, safety and quality. Knowledge of the sensory, physical, chemical and functional properties of food is applied in practical situations. Students investigate the food supply chain and value-adding techniques applied to food to meet consumer and producer requirements. Principles of dietary planning, adapting recipes, and processing techniques, are considered for specific nutritional needs of demographic groups. Occupational safety and health requirements, safe food handling practices, and a variety of processing techniques, are implemented to produce safe, quality food products. This course may enhance employability and career opportunities in areas that include nutrition, health, food and beverage manufacturing, food processing, community services, hospitality and retail.

YEAR 11 and 12 Pathways

Course Information Handbook 2027

Year 11 GEFST**UNIT 1 – FOOD CHOICES AND HEALTH**

This unit focuses on the sensory and physical properties of food that affect the consumption of raw and processed foods. Students investigate balanced diets, the function of nutrients in the body and apply nutrition concepts that promote healthy eating. They study health and environmental issues that arise from lifestyle choices and investigate factors which influence the purchase of locally produced commodities. Students devise food products, interpret and adapt recipes to prepare healthy meals and snacks that meet individual needs. They demonstrate a variety of mise-en-place and precision cutting skills, and processing techniques to ensure that safe food handling practices prevent food contamination. Students recognise the importance of using appropriate equipment, accurate measurement and work individually, and in teams, to generate food products and systems.

UNIT 2 – FOOD FOR COMMUNITIES

This unit focuses on the supply of staple foods and the factors that influence adolescent food choices and ethical considerations. Students recognise factors, including processing systems, that affect the sensory and physical properties of staple foods. They explore food sources and the role of macronutrients and water for health, and nutrition-related health conditions, such as coeliac and lactose intolerance, which often require specialised diets. Students consider how food and beverage labelling and packaging requirements protect consumers and ensure the supply of safe, quality foods.

Students work with a range of staple foods, adapt basic recipes and apply the technology process to investigate, devise, and produce food products to achieve specific dietary requirements. They evaluate food products and demonstrate a variety of safe workplace procedures, processing techniques and food handling practices.

Year 12 GTFST**UNIT 3 – FOOD SCIENCE**

This unit explores the societal, lifestyle and economic issues that influence food choices. Students research the effect of under-consumption and over-consumption of nutrients on health and investigate a range of diet-related health conditions that affect individuals and families. Using scientific methods, students examine the functional properties that determine the performance of food and apply these in the planning and preparation of food products and processing systems.

Students develop their expertise with technology and communication skills to implement strategies to design food products and processing systems. They select resources to meet performance requirements and use evaluation strategies to monitor and maintain optimum standards. Students follow occupational safety and health requirements, implement safe food handling practices and use a variety of foods and processing techniques to produce safe, quality food products.

UNIT 4 – THE UNDERCOVER STORY

This unit focuses on food spoilage and contamination and explores reasons for preserving food. Students investigate food processing techniques and the principles of food preservation. They examine the regulations which determine the way food is packaged, labelled and stored and how the principles of the Hazard Analysis Critical Control Point (HACCP) system are administered and implemented to guide the production and provision of safe food.

Students investigate the food supply chain and value-adding techniques applied to food to meet consumer and producer requirements. Food choices are often determined by location, income, supply and demand and the environmental impact of food provision. Students examine influences on the nutritional wellbeing of individuals that arise from lifestyle and cultural traditions. They implement principles of dietary planning and adapt recipes and processing techniques when considering specific nutritional needs of demographic groups. Students apply the technology process to address a product proposal and produce a preserved food product. They justify the equipment, resources and processing techniques used, and evaluate sensory properties. Students show the use of the preserved food product in another food product.



VOCATIONAL EDUCATION & TRAINING

CAREER LINK PROGRAM

A VOCATIONAL EDUCATION AND TRAINING PATHWAY

Entry to course subject to interview with student and parents.

The aim of this program is to allow those students who do not wish to undertake an ATAR pathway, to have the opportunity to complete a full Certificate qualification, either at TAFE, a private Registered Training Organisation (RTO), by profile funding or fee for service. Career Link is also known as VET Delivered to Secondary Students (VETdSS).

It is a dynamic pathway which will appeal to those students who wish to fast track their career and gain transferable skills which include communication, the ability to work as part of a team, problem-solving and self-management. An academic timetable is created for these students so that they have the opportunity to meet the requirements of WACE. The program is broken up into 2 parts as described below:

PART 1 – ACADEMIC/SCHOOL COMPONENT

Students attend school 3–4 days a week and complete a full academic program including:

- English
- Career and Enterprise, including Workplace Learning
- 4 other course/qualifications of their choice

Part 2 – Training/Workplace Component

On Thursday and/or Friday, students will attend one of the following training venues to complete qualifications in a vocational area of choice:

- TAFE,
- Private RTO,
- Pre-Apprenticeship in Schools (PAIS)
- Manadated course-based work placement.

Which days and number of days per week is determined by the RTO.

Students will undertake work placement in the area of their certificate qualification, i.e. a student completing the Certificate II in Painting with MPA, will work with a registered painter one day per week.

It is essential that students and parents understand the commitment required when applying for this program.

Depending on the course taken, there may be further costs associated with the Registered Training Organisation (RTO) and these will be passed onto parents, e.g. material costs.

To obtain further information, please book an appointment on the Subject Selection Online (SSO) Portal.

CERTIFICATE QUALIFICATIONS

The below qualifications are a proposed offering for the 2027 academic year.

DISCLAIMER

At the time of publication, no agreements have been entered into with a Registered Training Organisation (RTO) for the delivery of these qualification. The Units of Competency listed under each Certificate are an indication of course structure from prior years of delivery.

On the basis of interest from students in each of the below qualifications, the school will initiate a formal partnership agreement with a Registered Training Organisation (RTO) for the delivery of the qualification.

Course	Code	School Code	Cost (Per Year)
Certificate II in Workplace Skills	BSB20120	CT2WPS	\$139
Certificate III in Business [^]	BSB30120	CT3BUS	\$139
Certificate II in Engineering Pathways	MEM20422	CT2ENG	\$180
Certificate II in Hospitality	SIT20322	CT2HOS	\$325
Certificate II in Creative Industries (Live Production)	CUA20225	CT2CILP	\$185
Certificate II in Creative Industries (Media Production)	CUA20225	CT2CIM	\$185
Certificate III in Music	CUA30920	CT3MUS	\$110
Certificate II in Sport Coaching	SIS20321	CT2SPO	\$200
Certificate II in Visual Arts (Photography)	CUA20720	CT2VAP	\$130
Certificate III in Events	SIT30522	CT3EV	\$185.00

* Costs are estimates and are subject to change.

[^] Available only in Year 12 to students who have completed the Certificate II in Workplace Skills.

CERTIFICATE QUALIFICATION OUTLINES

Certificate qualifications are a pathway to WACE and employment for all students. Students will develop skills desired by employers and will place them in good stead for employment while embarking upon other studies post Year 12.

Students choose which qualifications they undertake in conjunction with their Course Counsellors and their parents.

Students will be required to complete the enrolment and induction with the appropriate Registered Training Organisation (RTO) partnering with Mount Lawley Senior High School to deliver the qualifications chosen.

Upon successful completion of all units of competencies in the qualifications, students will be issued with the appropriate qualification by the Registered Training Organisation (RTO).

NOTE: Entry is application-based. There is no guarantee of an offer.

CERTIFICATE II IN WORKPLACE SKILLS - BSB20120

DISCLAIMER

At the time of publication, no agreements have been entered into with a Registered Training Organisation (RTO) for the delivery of this qualification. The Units of Competency listed under each Certificate are an indication of course structure from prior years of delivery.

On the basis of interest from students the school will initiate a formal partnership agreement with an RTO for the delivery of this qualification.

NOTE: This is a one year program completed in Year 11.

This Certificate qualification will provide students with a nationally recognised qualification and provide preparation for employment and/or apprenticeships. This qualification reflects the role of individuals in a variety of entry-level Business Services job roles. These individuals may be starting out in the workforce.

This qualification also reflects the role of individuals who have not yet entered the workforce, and that are developing necessary skills in preparation for work. These individuals carry out a range of basic procedural, clerical, administrative and operational tasks that require self-management and technology skills. They perform a range of tasks using practical skills and fundamental operational knowledge in a defined context. Training and assessment will occur in the school environment. Students must complete 10 units of competency (5 core and 5 electives).

Completion of the qualification will provide students with invaluable employability skills. These workplace skills include:

Employability Skill	Industry/enterprise requirements for this qualification include:
Communication	communicating verbally with clients and colleagues
	drafting routine correspondence that meets the organisational standards of style, format and accuracy
Teamwork	working in a team environment to promote team commitment and cooperation
Problem-solving	choosing appropriate methods for communication and transferring information
	dealing with client enquiries and complaints
Initiative and enterprise	raising occupational health and safety issues with designated personnel
Planning and organising	planning and organising own work schedule for the day
	planning the layout of simple documents using appropriate software
Self-management	dealing sensitively with client needs and cultural, family and individual differences
	obtaining feedback on work performance and identifying opportunities for improvement
Learning	encouraging, acknowledging and acting on constructive feedback from team members
	using manuals, training booklets and online help to overcome difficulties
Technology	selecting, maintaining and using business technology appropriate to the task

Certificate II in Workplace Skills BSB20120 – INDICATIVE Units of Competency Year 11

Core Units	Elective Units
BSBOPS201 Work effectively in business environment	BSBOPS203 Deliver a service to customers
BSBWHS211 Contribute to the health and safety of self and others	BSBCRT201 Develop and apply thinking and problem solving skills
BSBPEF202 Plan and apply time management	SIRXOSM001 Identify and review social media and online platforms for organisational use
BSBSUS211 Participate in sustainable work practices	BSBTEC202 Use digital technologies to communicate in a work environment
BSBCMM211 Apply communication skills	BSBTEC201 Use business software applications

CERTIFICATE III IN BUSINESS - BSB30120

DISCLAIMER

At the time of publication, no agreements have been entered into with a Registered Training Organisation (RTO) for the delivery of this qualification. The Units of Competency listed under each Certificate are an indication of course structure from prior years of delivery.

On the basis of interest from students the school will initiate a formal partnership agreement with an RTO for the delivery of this qualification.

NOTE: This is a one year program completed in Year 12.

Prerequisites

Students must complete the Certificate II in Workplace Skills (formerly Certificate II in Business) in Year 11 as a prerequisite for this course, and be recommended.

This Certificate qualification will provide students with a nationally recognised qualification. This qualification reflects the role of individuals in a variety of Business Services job roles. It is likely that these individuals are establishing their own work performance.

Individuals in these roles carry out a range of routine procedural, clerical, administrative or operational tasks that require technology and business competence skills. They apply a broad range of competencies using some direction, judgement and relevant theoretical knowledge. They may provide technical advice and support to a team.

Training and assessment will occur in the school environment. Students must complete 13 units of competency (6 core and 7 electives).

Completion of the qualification will provide students with invaluable employability skills. For those students on an ATAR pathway the Certificate III in Business will provide them with information technology skills that will assist with University assessments, group work and study planning. These skills include:

Employability Skill	Industry/enterprise requirements for this qualification include:
Communication	communicating verbally with others in negotiation, training and questioning
	writing a range of simple documentation and communications
Teamwork	completing individual tasks to support team goals
	conveying workplace procedures and work instructions to team members
Problem-solving	resolving issues and conflicts with team members
	using manuals and other documentation to overcome problems with information technology or other office equipment
Initiative and enterprise	demonstrating individual responsibility for completing tasks
	suggesting improvements to support the development of improved work practices and team effectiveness
Planning and organising	contributing to planning processes with team members to meet expected outcomes
	gathering, organising and applying workplace information for the organisation's work processes and information systems
Self-management	identifying development needs and seeking training to fill needs
	monitoring and recording the performance of own work area
Learning	developing a comprehensive knowledge and understanding of products and services
	identifying priorities and pursuing personal work goals according to organisational objectives
Technology	using information communication technology to communicate with team members or clients
	using word processing packages, spread sheets or databases to produce written correspondence and reports

YEAR 11 and 12 Pathways

Certificate III in Business BSB30120 – INDICATIVE Units of Competency Year 12

Core Units	Elective Units
BSBCRT311 Apply critical thinking skills in a team environment	BSBTEC404 Use digital technologies to collaborate in a work environment
BSBTWK301 Use inclusive work practices	SIRXOSM003 Use social media and online tools
BSBPEF201 Support personal well-being in the workplace	SIRXMKT001 Support marketing and promotional activities
BSBSUS211 Participate in sustainable work practices	BSBPMG430 Undertake project work
BSBXCM301 Engage in workplace communication	BSBXCS302 Identify and report online security threats
SIRXOSM002 Maintain ethical and professional standards when using social media and online platforms	ICTSAS305 Provide ICT advise to clients
	SIRXPDK001 Advise on products and services

CERTIFICATE II IN ENGINEERING PATHWAYS - MEM20422
DISCLAIMER

At the time of publication, no agreements have been entered into with a Registered Training Organisation (RTO) for the delivery of this qualification. The Units of Competency listed under each Certificate are an indication of course structure from prior years of delivery.

On the basis of interest from students the school will initiate a formal partnership agreement with an RTO for the delivery of this qualificaton.

NOTE: This is a two year delivery completed over Years 11 and 12. In 2027 this class may have a Period 0, starting at 7:35am. This is a compulsory component of the course.

Prerequisites

Nil

This course is intended for students considering employment at the production operator level in manufacturing, engineering and related industry areas. Students will gain the basic level competencies required by an operator working in these areas.

Students will also acquire skills and knowledge in workplace communication, occupational safety and health, quality procedures, systems and planning plus industry specific skills such as:

- Carry out mechanical cutting;
- Perform routine oxy-acetylene welding;
- Perform manual heating and thermal cutting;
- Perform routine manual arc-welding;
- Perform manual production welding;
- Perform routine gas tungsten arc-welding;
- Perform routine gas metal arc-welding;
- Perform hand forging;
- Use workshop machines for basic operation;
- Use comparison and basic measuring devices;
- Use hand tools; and
- Use power tools and plan a complete activity.

YEAR 11 and 12 Pathways

Course Information Handbook 2027

Certificate II in Engineering Pathways MEM20413 – INDICATIVE Units of Competency Year 11/12

MEM13014A Apply principles of occupational health and safety in the work environment	MEMPE005A Develop a career plan for the engineering and manufacturing industry
MEMPE006A Undertake a basic engineering project	MSAENV272B Participate in environmentally sustainable work practices
MEM16006A Organise & communicate information	MEM18001C Use hand tools
MEM18002B Use power tools/hand held operations	MEMPE001A Use engineering workshop machines
MEMPE002A Use electric welding machines	MEMPE003A Use oxy-acetylene & soldering equipment
MEMPE004A Use fabrication equipment	MSAPMSUP106A Work in a team

CERTIFICATE II IN HOSPITALITY - CT2HOS

DISCLAIMER

At the time of publication, no agreements have been entered into with a Registered Training Organisation (RTO) for the delivery of this qualification. The Units of Competency listed under each Certificate are an indication of course structure from prior years of delivery.

On the basis of interest from students the school will initiate a formal partnership agreement with an RTO for the delivery of this qualification.

NOTE: This is a two year delivery completed over Years 11 and 12. In 2027 this class will have a Period 0 and Period 1, starting at 7:35am once a week. When class is scheduled for Period 5, time-in-lieu will be given. This is a compulsory component of the course.

Prerequisites

There are no prerequisites for this course, however, due to the requirements of this course, admission will be based on an interview to be conducted in Term 3, 2026. Applicants must have a minimum 87% attendance rate to obtain an interview for this course.

If you are interested in cooking and learning the skills required to work in the Hospitality industry, then the Certificate II in Hospitality will equip you with the underpinning knowledge and skills to commence your career pathway in this exciting industry.

Nationally Recognised Training

The Certificate II in Hospitality is designed to reflect the role of employees who perform a range of tasks in hospitality establishments. They may be multi-skilled across more than one functional area of hospitality. The Certificate II in Hospitality teaches you operative skills in the Hospitality Industry. Work would be undertaken in various hospitality enterprises where food is prepared and served.

Career Prospects

When you complete the Certificate II in Hospitality you can apply for the operational positions such as a room attendant, food waiter, drink waiter and function service staff in hotels, motels, resorts, clubs, guest houses, institutions and many hospitality related small businesses.

YEAR 11 and 12 Pathways

Course Information Handbook 2027

Award

Upon successful completion of all units of competencies in the course, students will be issued with a Certificate II in Hospitality. Should a student not complete the entire course then a Statement of Attainment will be given for the units successfully completed.

Delivery

This qualification will be delivered over 2 years commencing in Year 11. The structure includes a variety of practical activities however underpinning knowledge is also required to be demonstrated in theory lessons.

Certificate II in Hospitality SIT20322 – INDICATIVE Units of Competency Year 11/12

BSBTWK201 Work effectively with others	SITHIND006 Source & use information on the hospitality industry
SITHIND007 Use hospitality skills effectively	SITXCCS011 Interact with customers
SITXCOM007 Show social and cultural sensitivity	SITXWHS005 Participate in safe work practices
SITHIND006 Use hygienic practices for hospitality service	BSBCMM211 Apply Communication Skills
SITHCCC003 Prepare and present sandwiches	SITHFAB024 Prepare & serve non-alcoholic beverages
SITHFAB0025 Prepare and serve espresso coffee	SITXCCS009 Provide customer information & assistance

CERTIFICATE II IN CREATIVE INDUSTRIES (LIVE PRODUCTION) - CUA20225

DISCLAIMER

At the time of publication, no agreements have been entered into with a Registered Training Organisation (RTO) for the delivery of this qualification. The Units of Competency listed under each Certificate are an indication of course structure from prior years of delivery.

On the basis of interest from students the school will initiate a formal partnership agreement with an RTO for the delivery of this qualification.

NOTE

This is a two year delivery completed over Years 11 and 12.

Prerequisites

An interest in the entertainment and creative arts industries is desired. Students participating must be prepared to work on drama productions outside of school hours.

This qualification leads to further certificate, diploma and bachelor courses or employment. It relates specifically to the entertainment industry covering technical areas of basic lighting and audio work; stage management; scenic construction; providing staging support; providing ushering, ticketing and venue information; assisting in marketing; working with others; and occupational health and safety. The qualification develops communication skills, teamwork and problem-solving. It encourages initiative and enterprise, assists planning and organising, develops self-management, learning about productions and events and the use of specific technology.

YEAR 11 and 12 Pathways

Course Information Handbook 2027

The skills will be developed around a performance project and through supporting productions and events in the Tricycle Theatre and the school community like the Arts and Languages Festival. Certificate, diploma and bachelor qualifications are available, including at Western Australian Academy of Performing Arts (WAAPA) at ECU, that lead to an array of technical, management and design careers.

Certificate II in Creative Industries (Live Production) CUA20225 – Units of Competency Year 11/12

BSBTWK201 Work effectively with others	CUAIND211 Develop and apply creative arts industry knowledge
CUAWHS312 Apply work health and safety practices	CUAFOH211 Undertake routine front of house duties
CUALGT211 Develop basic lighting skills	CUASMT311 Work effectively backstage during performances
CPCCWHS1001 Prepare to work safely in the construction industry (white card)	CUADES201 Follow a design process
SITEEVT004 Provide event staging support	CUAPRP201 Develop basic prop construction skills

CERTIFICATE II IN CREATIVE INDUSTRIES (MEDIA PRODUCTION) - CUA20225

DISCLAIMER

At the time of publication, no agreements have been entered into with a Registered Training Organisation (RTO) for the delivery of this qualification. The Units of Competency listed under each Certificate are an indication of course structure from prior years of delivery.

On the basis of interest from students the school will initiate a formal partnership agreement with an RTO for the delivery of this qualification.

NOTE: One year course delivered in Year 11 only. Students who successfully complete the course will be invited to continue into the Certificate III in Screen and Media in Year 12

Prerequisites

No, an interest in media and the creative industries.

The Certificate II in Creative Industries is a hands-on, practical course designed for students who are passionate about media, film and digital content creation. This course provides a strong foundation in the creative industries, developing essential technical skills alongside teamwork and industry knowledge.

Throughout the year, students will learn how to:

- Film and edit video content using industry-standard equipment
- Capture and produce sound recordings
- Work with digital imaging and design tools
- Develop lighting and camera techniques
- Apply creative thinking and production skills in real-world projects

Students will also gain an understanding of how the creative industries operate, including workplace expectations, collaboration, and safe work practices.

This qualification is ideal for students who enjoy practical, project-based learning; have an interest in film, media production, photography or digital design; and are considering future pathways in creative industries, TAFE, or further study.

YEAR 11 and 12 Pathways

Course Information Handbook 2027

Successful completion of the course contributes towards WACE and provides students with a nationally recognised qualification. Western Australia is entering a period of significant growth in the screen sector, driven by the development of the Perth Film Studios and increased government investment in film and television production. This is creating strong demand for skilled media professionals.

This pathway also establishes a clear progression into further study, including TAFE courses, university degrees in film, television and digital media, and specialist institutions such as SAE Creative Media Institute. Students would graduate with both a WACE and a nationally recognised qualification, alongside a portfolio of work, giving them a competitive advantage in further education and employment.

Pathway to Certificate III

Students who demonstrate a high level of skill, commitment and achievement in Certificate II may be invited to continue into Certificate III in Screen and Media in Year 12.

This advanced course builds on the skills developed in Certificate II, allowing students to further specialise in advanced camera work, video and audio editing, creative project development, and industry-focused media skills.

Together, these qualifications create a clear pathway into careers and further study in film, television, digital media, and the broader creative industries.

Certificate II in Creative Industries (Media Production) CUA20225 – Units of Competency Year 11/12

BSBTWK201 Work effectively with others	CUAIND211 Develop and apply creative arts industry knowledge
CUAWHS312 Apply work health and safety practices	CUAPOS211 Develop basic editing skills
CUASOU213 Assist with basic sound recordings	CUADIG212 Develop digital imaging skills
CUACAM211 Assist with basic camera shoots	CUADES201 Follow a design process
CUALGT211 Develop basic lighting skills	CUAPOS211 Perform basic vision and sound editing

CERTIFICATE III IN MUSIC - CUA30920

DISCLAIMER

At the time of publication, no agreements have been entered into with a Registered Training Organisation (RTO) for the delivery of this qualification. The Units of Competency listed under each Certificate are an indication of course structure from prior years of delivery.

On the basis of interest from students the school will initiate a formal partnership agreement with an RTO for the delivery of this qualification.

NOTE: This is a two year qualification completed over Years 11 and 12.

Prerequisites

Students must have completed up to the Year 10 music course and achieved satisfactory results from the previous year, or have approval from the music department. This is a broad course that can include musicians from a Western Art, Jazz and Contemporary background.

AUDITION REQUIRED AS PART OF ENTRY TO COURSE.

YEAR 11 and 12 Pathways

Course Information Handbook 2027

This qualification is for those students who have an interest in music and are keen to develop skills for the music industry. Our qualification has a strong performance focus, incorporating solo and ensemble playing in a wide array of concerts, festivals and recitals. Students will also learn to administrate and assist in the running of these events and develop skills working backstage and providing stage support.

Students are supported in planning and pursuing a career in the Arts industry, learning important applications for copyright as a performer, recording artist and composer. Students achieving competency in all areas of this Certificate will be industry ready with an understanding of both the creative and practical application of musical skill.

Certificate III in Music (Performance) CUA30920 – INDICATIVE Units of Competency Year 11/12 (units may be subject to change)

CUACMP311 Implement copyright arrangements	CUAIND313 Work effectively in the music industry
CUAIND314 Plan a career in the creative arts industry	CUAMLT311 Develop and apply aural perception skills
CUAMLT313 Develop musical notation skills	CUAMPF213 Perform simple repertoire in ensembles
CUAMPF311 Develop technical skills for musical performances	CUAMPF312 Prepare for musical performances
SITEEVT004 Provide event staging support	CUAMPF214 Perform music from simple written notation
CUAMPF416 Perform music as a soloist	

CERTIFICATE II IN SPORT COACHING - SIS20321

DISCLAIMER

At the time of publication, no agreements have been entered into with a Registered Training Organisation (RTO) for the delivery of this qualification. The Units of Competency listed under each Certificate are an indication of course structure from prior years of delivery.

On the basis of interest from students the school will initiate a formal partnership agreement with an RTO for the delivery of this qualification.

NOTE: This is a two year qualification completed over Years 11 and 12.

Prerequisites

None

This qualification provides the PRACTICAL skills and knowledge for an individual wishing to work in the sport and recreation industry in a generalist capacity. Likely functions for someone with this qualification can include providing support in the provision of sport and recreation programs, grounds and facilities maintenance, retail and customer service assistance, administrative assistance or bar and café service in locations such as fitness centre, outdoor sporting grounds or complexes or aquatic centres. All job roles are performed under supervision.

Job Roles

The following are indicative job roles for this qualification:

- recreation assistant;
- administration assistant;
- grounds assistant; or
- retail assistant.

YEAR 11 and 12 Pathways

Course Information Handbook 2027

Employability Skills

- Nationally recognised qualification;
- Communication, teamwork, problem-solving, self-management, planning and organisation, technology and enterprise; and
- Attainment of a First Aid certificate.

Who can do this course?

This qualification is suitable for all students in Year 11 and 12. Both university bound students as well as potential TAFE students will benefit from the skills and qualifications provided through the completion of this course.

Award

Upon the successful completion of all units of competencies in the course, students will be issued with a Certificate II in Sport Coaching. Should a student not complete the entire course then a Statement of Attainment will be given for the units successfully completed.

Certificate II in Sports Coaching SIS20321 – INDICATIVE Units of Competency Year 11/12

HLTAID011 Provide first aid	SIRXWHS001 Work safely
SISSSCO002 Work in a community coaching role	SISSNTB001 Conduct netball coaching sessions with foundation level participants
SISSPAR009 Participate in conditioning for sport	SISSSCO001 Conduct sport coaching sessions with foundation level participants
SISSSOF003 Officiate sport competitions	SISSSOF002 Continuously improve officiating skills and knowledge
SISXCAI001 Provide equipment for activities	

CERTIFICATE II IN VISUAL ARTS (PHOTOGRAPHY) - CUA20720

DISCLAIMER

At the time of publication, no agreements have been entered into with a Registered Training Organisation (RTO) for the delivery of this qualification. The Units of Competency listed under each Certificate are an indication of course structure from prior years of delivery.

On the basis of interest from students the school will initiate a formal partnership agreement with an RTO for the delivery of this qualification.

NOTE: This is a two year qualification completed over Years 11 and 12.

Prerequisites

None

This qualification prepares students for professional and recreational photography and gives them life long skills applicable to most industries. Students learn how to control digital cameras enabling them to produce photographs of a professional level quality. Students learn to photograph both outdoors and in a studio environment undertaking shoots such as fashion, macro-photography and portraits.

Client directed tasks are also carried out, involving students working on projects as if they were a professional photographer. They produce images for a wide variety of 'clients' in the form of websites, brochures, flyers and one off commissioned works of art. They produce their images in both colour and black and white and conduct their own mini exhibition at the conclusion of their course.

Certificate II in Visual Arts (Photography) CUA20720 – INDICATIVE Units of Competency Year 11/12

BSBWHS211 Contribute to health and safety of self and others	CUAACD201 Develop drawing skills to communicate ideas
CUAPPR211 Make simple creative work	CUARES202 Source and use information relevant to own arts practice
CUADES201 Follow a design process	CUADIG212 Develop digital imaging skills
CUADIG315 Produce digital images	CUADIG303 Produce and prepare photo images
CUAPHI312 Capture photographic images	BSBTWK201 Work effectively with others

CERTIFICATE III IN EVENTS - SIT30522

DISCLAIMER

At the time of publication, no agreements have been entered into with a Registered Training Organisation (RTO) for the delivery of this qualification. The Units of Competency listed under each Certificate are an indication of course structure from prior years of delivery.

On the basis of interest from students the school will initiate a formal partnership agreement with an RTO for the delivery of this qualification.

NOTE: This is a two year qualification completed over Years 11 and 12.

Prerequisites

There are prerequisites for this course, however, due to the requirements of this course, admission will be based on an interview to be conducted in Term 3 2026.

Learn to assist in managing events, from planning to show day and event follow up. You'll be introduced to audio and visual industry standard technologies and be encouraged to develop your creative skills. This course blends fundamental concepts of business administration with the creative arts industry, providing insights into the practical tasks that sit behind the events sector.

Events enrich our culture and are held to educate, celebrate, inform and entertain.

The Certificate III in events will give you the skills to assist in managing events, from the planning through to show day and the follow up after the event. You'll be introduced to industry standard technologies for lighting, sound and audio-visual and begin to develop your creative skills so you can deliver professional events to your clients.

YEAR 11 and 12 Pathways

Course Information Handbook 2027

Our on-site trainers have strong industry links and you will be given opportunities to put your skills into practice with live work events organised by your trainer.

Certificate III in Events – INDICATIVE Units of Competency Year 11/12

BSBTWK201 Work effectively with others	BSBTEC303 Create electronic presentations
SITEEV020 Source and use information on the events industry	CUALGRT211 Develop basic lighting skills
SITEEV022 Provide event production support	CUAMKG311 Assist with marketing and promotion
SITXCC014 Provide a service to customers	CUASOU211 Develop basic audio skills and knowledge
SITXCOM007 Show social and cultural sensitivity	SITEEV021 Administer event registrations
SITXWHS005 Participate in safe work practices	SITXMPR010 Create a promotional display or stand
BSBTEC301 Design and produce business documents	

FOR MORE INFORMATION

For more information about courses, pathways, prerequisites, assessment requirements and subject selection, students and parents are encouraged to contact the relevant Learning Area. Learning Area Leaders can provide advice on course suitability, future study and career pathways, and subject requirements.

Please contact the Senior School Office on (08) 9265 1535 or via mountlawley.shs.seniorschooladmin@education.wa.edu.au and ask to speak with the relevant Learning Area Leader.

ENGLISH

Rebecca Davis
Program Coordinator - English
rebecca.davis@education.wa.edu.au

HEALTH & PHYSICAL EDUCATION

Adam Zen
Program Coordinator - Health & Physical Education
adam.zen@education.wa.edu.au

HUMANITIES & SOCIAL SCIENCES

Kieren Pearce
Program Coordinator - Humanities and Social Sciences
kieren.pearce@education.wa.edu.au

MATHEMATICS

Eric Tang
Program Coordinator - Mathematics
eric.tang@education.wa.edu.au

SCIENCE

Mat Winter
Program Coordinator - Science
mat.winter@education.wa.edu.au

LANGUAGES

Louise Chapman
Program Coordinator - Languages
louise.chapman@education.wa.edu.au

THE ARTS Visual Arts

Lynda Kuntjy
Program Coordinator - Visual Arts (Media and Visual Art)
lynda.kuntjy@education.wa.edu.au

THE ARTS Performing Arts

Michelle deRozario
Program Coordinator - Performing Arts (Drama and Music)
michelle.derozario@education.wa.edu.au

TECHNOLOGIES

Bill Angus
Program Coordinator - Technologies
bill.angus@education.wa.edu.au

VET / CAREERS

David Toothill
Program Coordinator - VET/Careers
david.toothill@education.wa.edu.au

SENIOR SCHOOL LEADERSHIP

Maria Camilleri – Associate Principal, Senior School
maria.camilleri@education.wa.edu.au

Oversees enrolments, quality teaching programs, and student learning outcomes.

Luke Crick – Assistant Associate Principal, Senior School
luke.crick@education.wa.edu.au

Responsible for attendance, uniform, behaviour standards, and ensuring a positive school environment for Year 11 and 12 exams



MOUNT LAWLEY SENIOR HIGH SCHOOL
An Independent Public School

65 Woodsome Street, Mount Lawley WA 6050 | 08 9265 1535 (Senior School Administration)
lawley.wa.edu.au | mountlawley.shs.seniorschooladmin@education.wa.edu.au